

# Tahoe Boat Inspections

Watercraft Reference Book

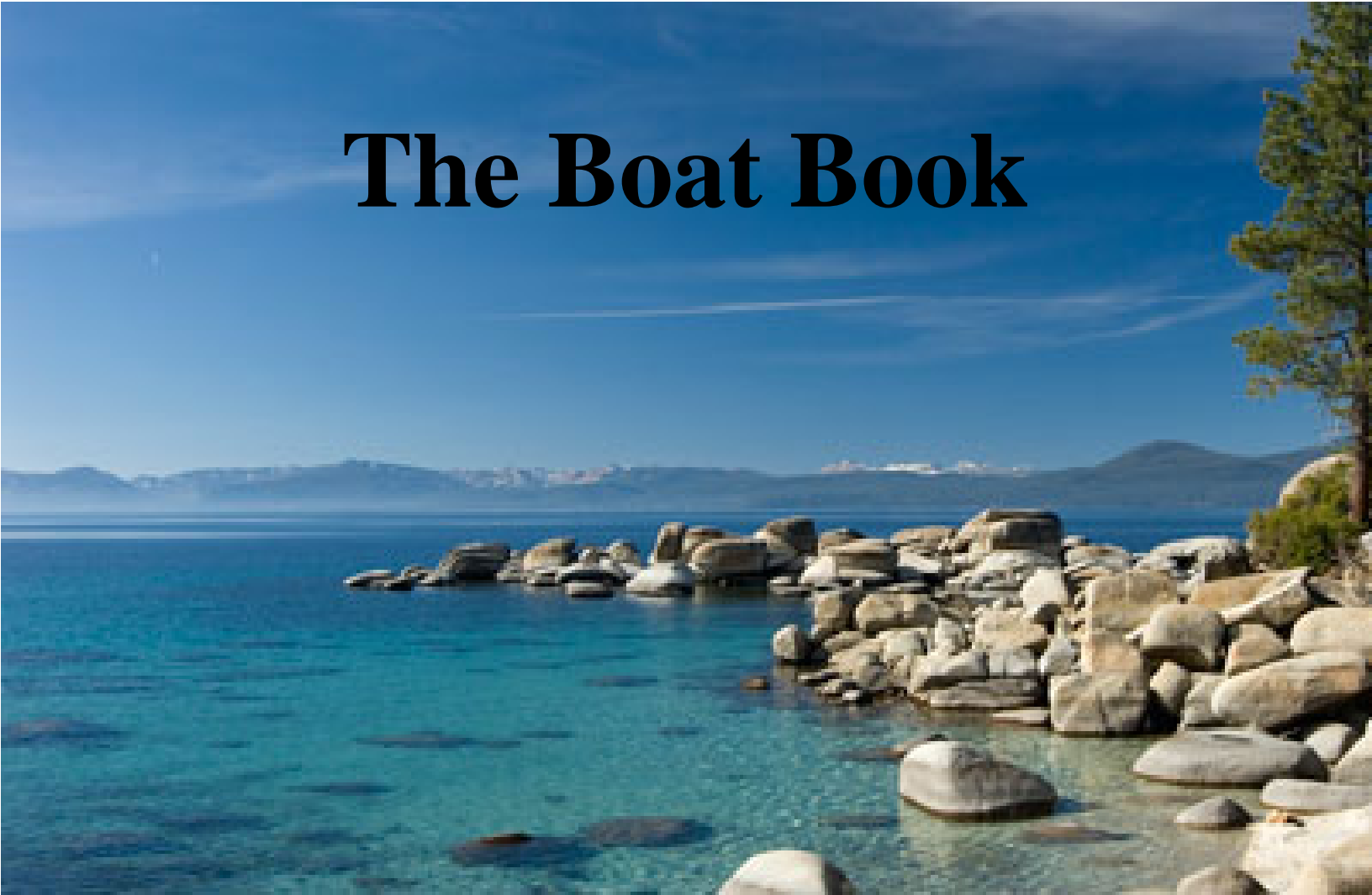

## The Boat Book



Wednesday, April 19, 2017

# Table of Contents

<b>Chapter 1: What is a Boat</b>	<b>Page 1</b>
<b>Chapter 2: Types of Watercraft</b>	<b>Page 3</b>
Ski Boats	Page 3
Wakeboard Boats	Page 5
Off-Shore Racers	Page 7
Pleasure Boats	Page 9
Fishing Boats	Page 13
Sail Boats	Page 16
Wooden Boats	Page 18
Personal Watercraft (PWC)	Page 20
<b>Chapter 3: Types of Marine Engines</b>	<b>Page 23</b>
Carbureted Two-Stroke	Page 23
Electronic Fuel Injected 2 Strokes	Page 24
Two-Stroke Direct Fuel Injected (DFI)	Page 25
Carbureted Four-Stroke	Page 26
Electronic Fuel Injected (EFI) Four Stroke	Page 27
<b>Chapter 4: Cooling Systems</b>	<b>Page 28</b>
Open Loop	Page 28
Decontaminating Open Loop Cooling Systems	Page 29
Closed Loop	Page 30
Decontaminating Closed Loop Cooling Systems	Page 30/31
Air Cooling	Page 32
Sea Pumps and Impellers	Page 33
<b>Chapter 5: Drives and Propulsion</b>	<b>Page 34</b>
Stern Drives	Page 34
Decontaminating a Stern Drive	Page 35
V Drives	Page 37
Direct Drives	Page 38
Decontaminating a V Drive or Direct Drive	Page 38
Outboards	Page 41
Electric	Page 42
Jet	Page 42
Decontaminating an Outboard	Page 42
Jet Drives	Page 45
Decontaminating a Jet Drive (PWC's)	Page 46
Decontaminating a Jet Drive (Boats)	Page 52

<b>Chapter 6: Optional Raw Water Systems</b>	<b>Page 55</b>
<b>Ballast Systems</b>	<b>Page 56</b>
<b>Single Intake</b>	<b>Page 56</b>
<b>Multiple Intakes</b>	<b>Page 56</b>
<b>Gravity Fill</b>	<b>Page 56</b>
<b>Removable Systems</b>	<b>Page 57</b>
<b>Sea Cock</b>	<b>Page 58</b>
<b>Sea Strainer</b>	<b>Page 58</b>
<b>Check Valve</b>	<b>Page 58</b>
<b>Vented Loop</b>	<b>Page 58</b>
<b>Manifold</b>	<b>Page 58</b>
<b>Solenoid Valves</b>	<b>Page 59</b>
<b>Aerator Pump</b>	<b>Page 59</b>
<b>Reversible Pump</b>	<b>Page 60</b>
<b>Ballast Tanks/Bags</b>	<b>Page 61</b>
<b>Through Hulls</b>	<b>Page 64</b>
<b>Bilge Oil Separators</b>	<b>Page 66</b>
<b>Air Conditioning Units</b>	<b>Page 67</b>
<b>Intakes</b>	<b>Page 67</b>
<b>Sea Strainer</b>	<b>Page 67</b>
<b>Reversible Pump</b>	<b>Page 67</b>
<b>Condenser</b>	<b>Page 68</b>
<b>Discharge Port</b>	<b>Page 68</b>
<b>Generators</b>	<b>Page 69</b>
<b>Cabin Heaters</b>	<b>Page 70</b>
<b>Sinks and Showers</b>	<b>Page 71</b>
<b>Fill/Intakes</b>	<b>Page 71</b>
<b>Sea Strainer</b>	<b>Page 72</b>
<b>Pump</b>	<b>Page 72</b>
<b>Storage Tank</b>	<b>Page 72</b>
<b>Accumulator</b>	<b>Page 72</b>
<b>Check Valve</b>	<b>Page 72</b>
<b>Water Heater</b>	<b>Page 72</b>
<b>Pressure Valve</b>	<b>Page 72</b>
<b>Sinks</b>	<b>Page 72</b>
<b>Showers</b>	<b>Page 72</b>
<b>Raw Water Deck Showers</b>	<b>Page 73</b>
<b>'Heads'</b>	<b>Page 74</b>
<b>Live/Bait Wells</b>	<b>Page 75</b>
<b>Chapter 7: Boat Terminology</b>	<b>Page 77</b>
<b>Chapter 8: Specific Manufacturers</b>	<b>Page 80</b>
<b>Fishing Boats:</b>	<b>Page 81</b>
<b>Alumaweld</b>	<b>Page 81</b>
<b>Lund</b>	<b>Page 83</b>
<b>Ranger</b>	<b>Page 85</b>
<b>Tracker</b>	<b>Page 86</b>
<b>Trophy</b>	<b>Page 87</b>

<b>Pleasure Boats:</b>	<b>Page 89</b>
<b>Bayliner</b>	<b>Page 89</b>
<b>Maxum</b>	<b>Page 92</b>
<b>Chris Craft</b>	<b>Page 94</b>
<b>Four Winns</b>	<b>Page 95</b>
<b>Pontoon</b>	<b>Page 96</b>
<b>Sail Boats:</b>	<b>Page 98</b>
<b>Grenada</b>	<b>Page 98</b>
<b>Hobie Cat</b>	<b>Page 99</b>
<b>MacGregor</b>	<b>Page 100</b>
<b>Ski/Wakeboard Boats:</b>	<b>Page 101</b>
<b>Malibu</b>	<b>Page 101</b>
<b>Mastercraft</b>	<b>Page 102</b>

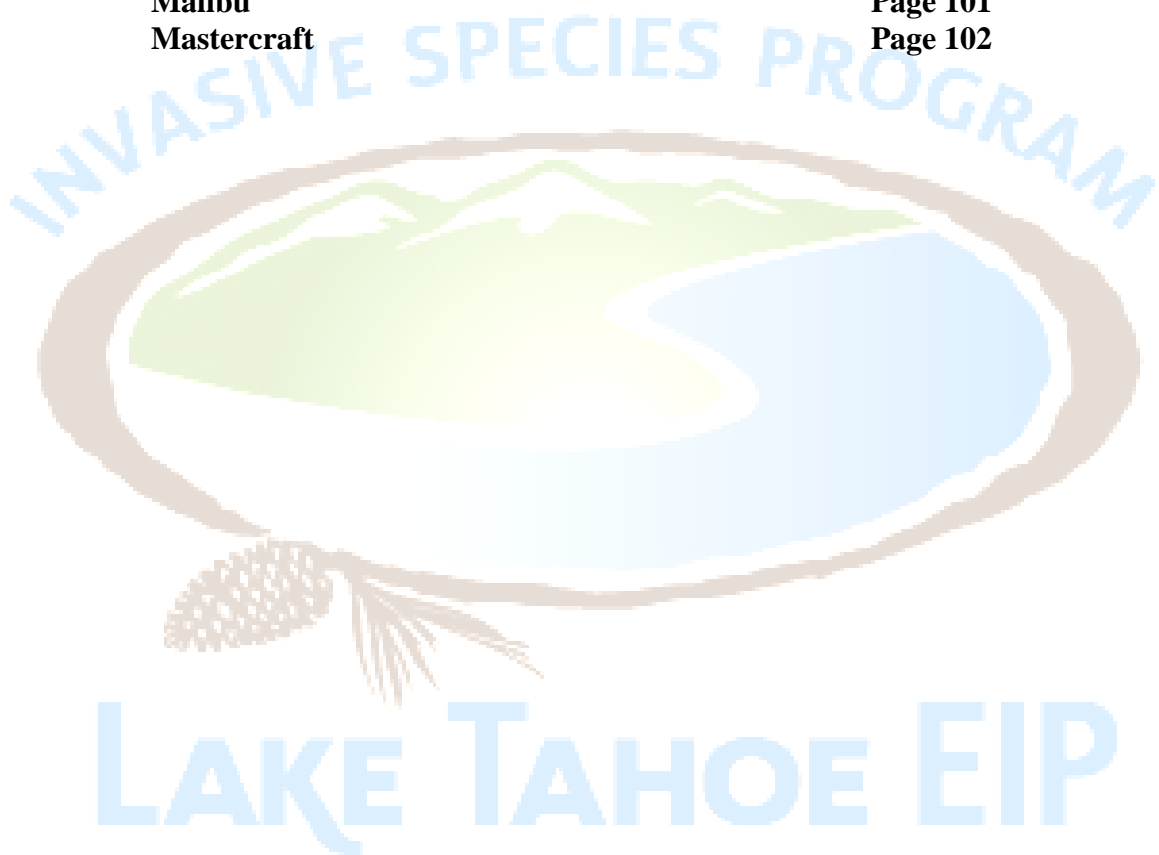

# Chapter 1: What is a Boat?

Fig. 1

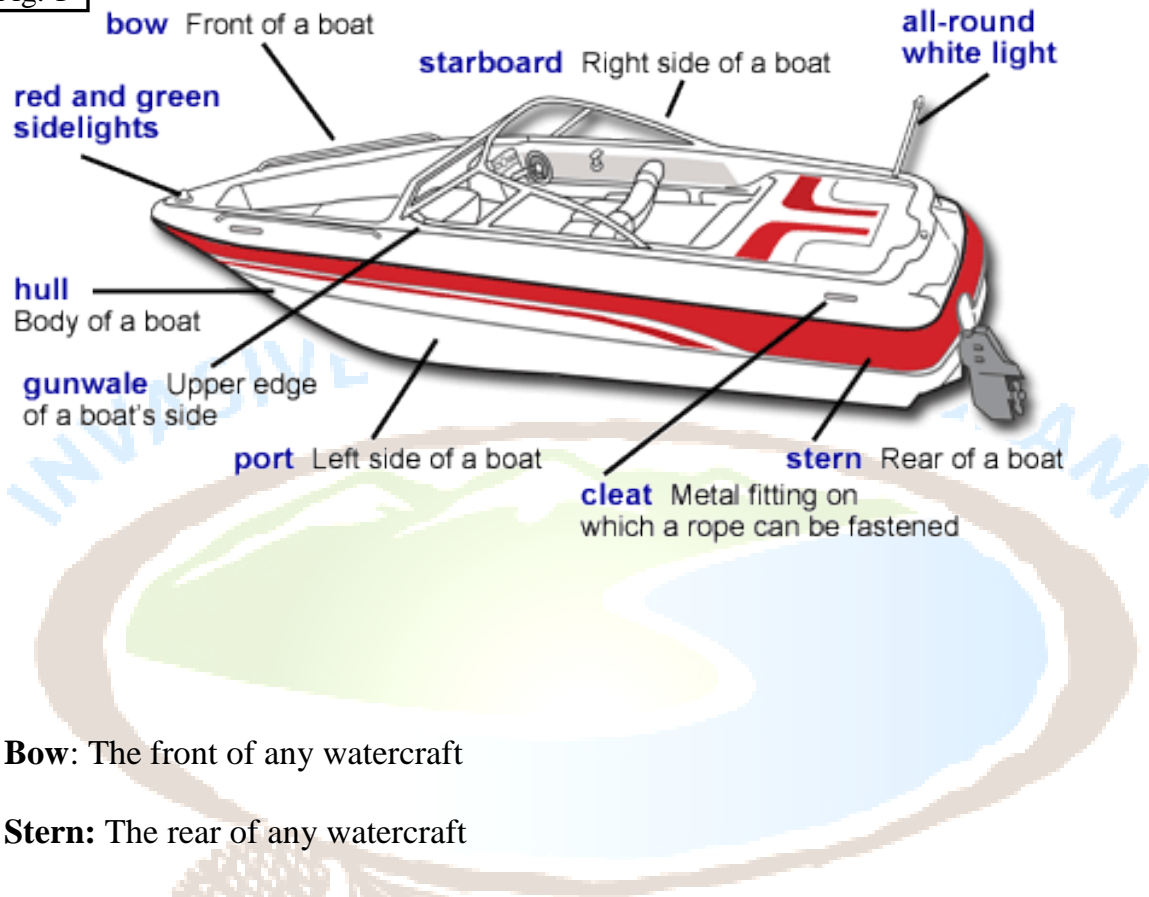

**Bow:** The front of any watercraft

**Stern:** The rear of any watercraft

**Starboard:** The right side of any watercraft

**Port:** The left side of any watercraft

**Red and Green sidelights:** Navigation lights, Red = Port, Green = Starboard.

**All-Round white light:** Anchor light or more commonly known as “Stern light”

**Cleat:** Metal fitting used for attaching lines for tying off the watercraft

**Hull:** The running surface of the vessel

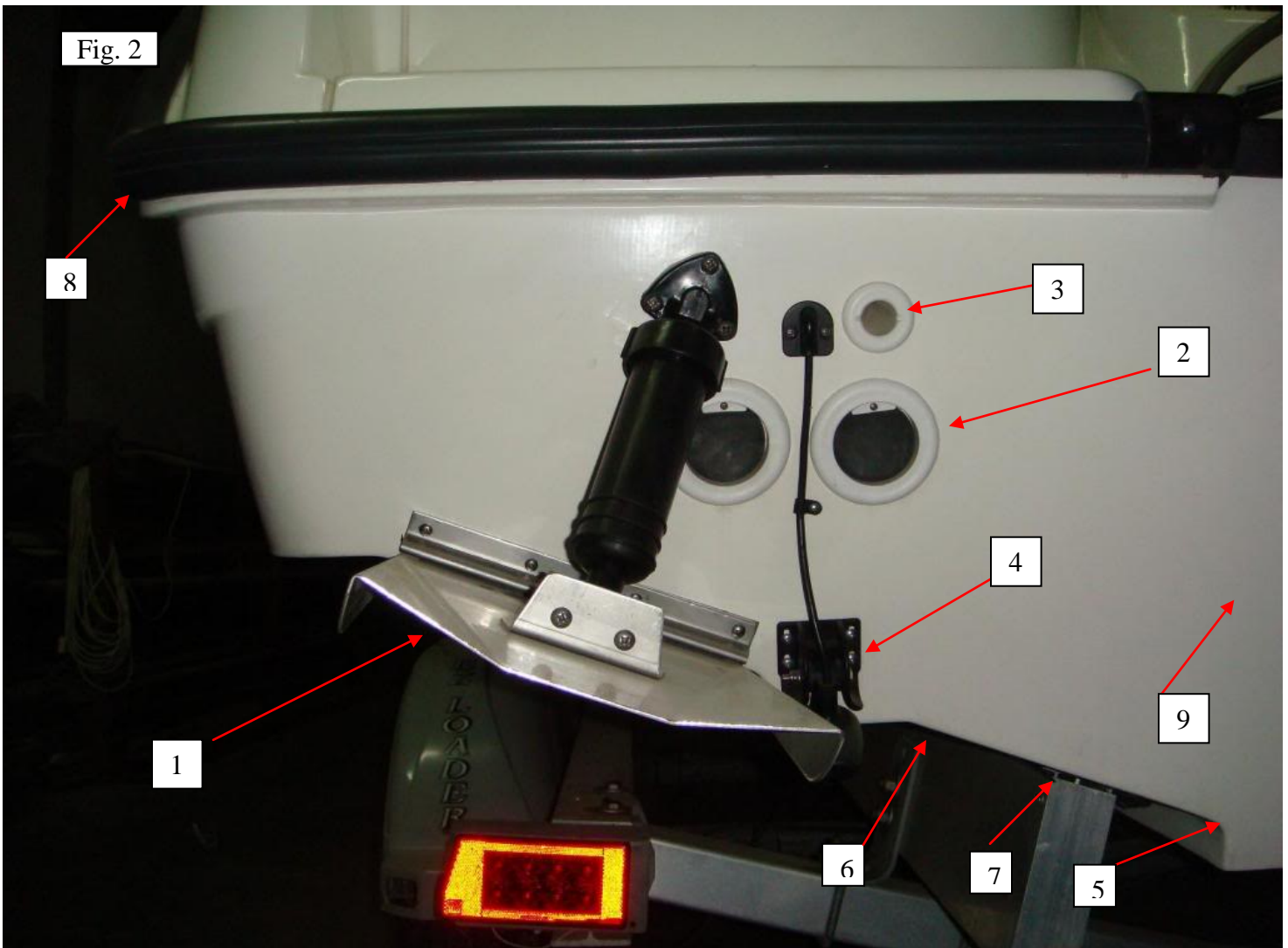

Fig. 2

1. Trim Tabs: help boats get on plane at lower speeds and stabilize uneven loads.
2. Scupper: one way water drains, also known as a “self bailer”
3. Through Hull Fitting: can be used for many things such as an air vent for ballast tanks or water exits for different systems. The one shown in the picture is the water exit for a bilge pump.
4. Transducer: sonar device that helps find bottom depth, fish and rocks.
5. Chine: sharp angel in the hull to add grip and stabilize the boat.
6. Strake: a running surface on a boat hull.
7. Bunk: carpeted piece of wood that a boat will sit on while on the trailer.
8. Rub Rail: long strip of rubber or hard plastic that hides the seam of the two halves of the boat. It also acts as a fender.
9. Transom: surface that forms the stern of a boat.

# Chapter 2: Types of Watercraft

In this chapter we will go over the following types of watercraft in more detail

- Ski Boats
- Wakeboard Boats
- Off-Shore Racers
- Pleasure Boats
- Fishing Boats
- Sail Boats
- Wooden Boats
- Personal Water Crafts (PWC's)
- Inflatables and Rigid Hulled Inflatables

Although some are detailed separately, they may be considered the same type of watercraft (off-shore racers, are considered pleasure boats for example).

## ***Ski Boats***

Ski boats have a sleek look and, a low free board, meaning they sit close to the water. They are designed to have as little wake as possible when they pass through the water. They do not carry STOCK ballast tanks however sometimes if they have one person in the family that likes to wakeboard they may have added “Fat sacks” or ballast bags to the boat. These boats are becoming less common.

### **Drives used:**

- Direct Drive
- Outboard

### **These systems could be on board:**

- Fresh water shower
- Raw water shower
- Heater

### **Engine Types: *\*\*These are the most common, there can be more\*\****

- Mercury 350 MAG Tournament ski V8
- Mercury Black Scorpion 6.2 V8
- PCM 5.8 V8
- PCM 8.2 Python V8
- Johnson 150 V6 OB
- Evinrude 150 V6 OB

### **Brands:**

- |                              |              |            |
|------------------------------|--------------|------------|
| American Skier               | Eagle Air    | Sportique  |
| Calabria                     | Epic Boats   | Supra      |
| Cobalt (1998-99 only)        | Malibu Boats | Supreme    |
| Correct Craft<br>(Nautiques) | Master Craft | Tiga       |
| Dyna-Ski                     | MB Sports    | Tiger Trax |
|                              | Moomba       | Volante    |

# Examples of Ski Boats



2010 Ski Nautique Direct Drive



2011 Dyna-Ski, 200hp two stroke DI evinrude E-TEC



1993 Supra TS6M



1997 Ski Sanger DX11



## Wakeboard boats

Wakeboard boats are designed to make a large wake; the purpose of this is so the boarder can use the wake as a jump. To make a wake larger, most boats use a ballast system (pg 55) but some use a wake wedge (a wedge to sink the rear of the boat) mounted on the transom or both. Some boats only have one ballast tank and others have up to five tanks. In most cases these tanks are filled from the bottom or transom area by pumps. You can tell wake boats apart because of their low freeboard (meaning they sit close to the water), extreme graphics, large tow towers and ballast tank through hulls.

Generally speaking, wakeboard boats are V-drive boats. This means they are an inboard boat with the engine placed backwards in the rear of the boat. This is done to keep more weight in the back of the boat and make the wake larger and steeper. Some wakeboard boat models are direct drive boats where the engine is in the middle of the boat.

### Drives used:

V-Drive

### These systems could be on board:

Raw water shower  
Fresh water shower  
Raw water sinks  
Fresh water sinks  
Heaters  
Head  
Ballast tanks  
Ballast Bags

### Engine types:

PCM V8 (5.7-8.1)  
Indmar V8 (5.0-8.1)  
Mercury Black Scorpion V8 6.2

### Brands:

(See ski boat brands)

Brand specific wake board boat information can be found at the end of this book.

Malibu – pg 101

Mastercraft – pg 102



## Examples of Wakeboard Boats



2010 MB Sport F21



Master Craft X45



2011 Malibu Wakesetter 23 LSV



2010 Correct Craft Super Air Nautique 230

## ***Off-Shore Racers***

As a type of Pleasure Boat, the watercraft in this class are so called because they are made to go very fast 'off-shore' where they have room to reach higher speeds and can take you quickly across large distances. They are available to the average consumer (as long as they have \$750,000) and are "street" legal. They are usually very long (around 36'-50') and sleek and contain a lot more horsepower than most watercraft (1000 to 4000 total horsepower).

They are commonly set up as a very deep V hull, catamaran, or tri-hull race boats.

Because these boats are so powerful and large, they require large bodies of water to get up to their top speeds when not off-shore. Unfortunately for us, almost all of those water bodies in the western US are infested with mussels. For this reason, you will find that they have frequently been in Lake Mead, Havasu, and Shasta. Do a thorough inspection for mussels, but we no longer REQUIRE an engine flush for CDD vessels that are not reported to have been in infested bodies of water in the past 365 days.

### **Drives used:**

Outboards, Inboard/Outboards

### **These systems could be on board:**

These boats are made to go fast and usually don't have many other systems on board. Ballast systems are rare and help to stabilize the vessel at high speeds.

### **Engine types:**

Sterling

Mercury Racing

As these vessels are so custom, there are many other possibilities here

### **Outdrive Types:**

Mercury Racing Bravo1 XR Sportmaster

Mercury Racing NXT and NXT6

Mercury Racing M8

There are loads of possibilities here as well, but these are the most popular.

### **Brands:**

Baja

Donzi

Cigarette

Fountain

Eliminator

Scarab by Wellcraft

Hallett

There are also many custom brands here, but these are the most common that we see.

## Examples of Off-Shore Race Boats



Cigarette Top Gun



Fountain Lightning



Eliminator Daytona

## ***Pleasure Boats***

The “pleasure boat” class has the largest variety of boats. These are the family fun boats, designed for being universal. Unlike ski boats that have a similar design these boats have many different styles. Some made for more specific needs like boat camping, going fast or just packing as many people as possible on board. You will notice that some have wakeboard towers and or say wake edition on them, this DOES NOT make them wakeboard boats. Because this class is so large you will find most engine varieties.

### **Drives used:**

Stern Drive	Jet Drive
Outboard	Direct Drive
POD drive	Surface Drive

### **These systems could be on board:**

Fresh water shower	Raw water shower	Fresh water sinks
Raw water sinks	Head	Heater
Generator	Air conditioner	Diverted exhaust system

### **Engine types: (most common)**

Mercury MerCruiser I4 (3.0)  
Mercury MerCruiser V6 (4.3)  
Mercury MerCruiser V8 (5.0-8.2) the plastic cowling may read (305-496)  
Mercury Racing V8 NA (525)  
Mercury Racing V8 FI (600-1350) all have forced induction (ie superchargers, turbo)  
Mercury Pro I6 FI (250hp-300hp) forced induction  
Mercury Verado I6 FI (225hp-300hp) forced induction  
Mercury Verado I4 FI (150hp-200hp) forced induction  
Mercury Optimax Pro XS I3 DFI (115hp)  
Mercury Optimax Pro XS V6 DFI (150hp-250hp)  
Mercury Optimax V6 DFI (135hp-250hp)  
Mercury Optimax I3 DFI (75hp-125hp)  
Mercury Four I4 (50hp-150hp)  
Mercury Four I3 (25hp-40hp)  
Mercury Four I2 (8hp-20hp)  
Mercury Four 1 (2.5hp-6hp)  
Mercury Racing I6 FI (350hp) forced induction  
Mercury Racing Optimax xs V6 DI (300hp)  
Mercury Racing Optimax Sport V6 DI (250hp)  
Volvo Penta V6 (4.3)  
Volvo Penta V8 (5.0-8.1) or (305-496)  
Volvo Penta IPS (310hp-800hp)  
OMC (5.0-7.4) GM  
OMC Ford engines  
Evinrude Outboards  
Johnson Outboards  
Many others...

## Brands:

Adrenaline Powerboats  
Adrenaline Marine  
Advantage Boats  
Allison Boats  
Alumacraft  
Alumaweld  
Aluminum Chambered Boats  
American Tugs  
Apache Power Boats  
Arima Marine  
International  
Atlantic Boat Company  
Baja  
Bay Craft  
Bayliner Boats  
Bay Master  
Belkov Yacht  
Bent Jespersen  
Boatbuilders  
Bentz River Jetboats  
Bill Munson Boats  
Blue Water Boats  
Boston Whaler  
BradleyBoat  
Bryant Boats  
Bullet Boats  
C-Dory Boats  
CF Boats  
C-Hawk Boats  
Camano Yachts  
America  
Commander Boats  
Campion Marine  
CanMar  
Cape Horn Offshore Boats  
Caravelle Powerboats  
Cascade Yacht Builders  
Century Champion Boats  
Chaparral Boat  
Checkmate  
Chris Craft  
Cigarette Racing  
Clark Island Boat Works  
Cobalt Boat  
Cobia  
Cobra Performance Boats  
Conquest Boats  
Cougar Custom Boats  
Crownline  
D. Murphy Sport Boats  
Davis Boats  
Radoncraft  
Deep Impact Boats  
Des Champ & Jackson Boatbuilders  
Don Smith Powerboats  
Donzi Marine  
Doral Boats  
Dragon Powerboats  
Eagle One  
Ebtide  
EdgeWater Power Boats  
Egg Harbor  
Egret Boat Company  
Ellis Boat Company  
Eliminator  
F&S Boatworks  
Fab-Tech  
Farallon  
Fiber Works  
Fiesta Boats  
Firefish  
Formula  
Fortier Boats  
Fountain Boats  
Four Winns  
G3 Boats  
Glastron  
Global Marine  
Specialties  
Golden Pond Classic Boats  
Gozzard  
Grey Barn Boatworks  
Hacker-Craft  
Hallett Boats  
Harbercraft  
Hewes  
Hewes Craft Hike Metal  
Hourston Glascraft  
HTM2 Hight Torque Marine  
Hurricane Deck Boats  
Hustler  
Inshore Powerboats  
Intrepid Power Boats  
Island Hopper  
Island Pilot  
Island Runner Boats  
Inland Seas Boat Company  
Jaguar Marine  
John Williams Boat Company  
Kachina Power Boats  
Kazulin  
Kenner Boats  
Key West  
Klamath Boats  
Lagoon Royal  
Lake & Bay Boats  
Larson Boats  
Lavey Craft  
Performance Boats  
Legend Boats  
Mad Trapper  
Magic Powerboats  
Magnum Marine  
Mako Marine  
Malcom L. Pettegrow Custom Boats  
Mangrove Boats  
Mathew Brothers  
Maxum  
McGray Boatbuilders  
Mederios Boat Works  
MetalCraft Marine  
Milan  
Mirage  
Monaro Marine  
Montana Boat  
Monterey Boats  
Motion Marine  
Munson  
Newport Classic Boats  
Newport Runabout  
Nexus  
Nordic Boat  
Nordic Tugs  
Nordin Custom Boats

Norstar Boats	Seal Boats USA	Tahoe Boats
Old Wharf Dory	SeaRay Boats	TechniKal
Outerlimits	Shamrock Boats	Thunder Jet Tracker
Pantera Boats	Shelter Island Runabout	Marine
Pavati Marine	Skeeter Skiff Craft	Triumph Boats
Penn Yan	SkipJack Boats	Tuffy Boats
Phantom Boats	Smoker Craft	Ultra Custom Boats
Piranha	Sonic USA	Van Dam
Pluckebaum	Southern Star	Vanquish Boats
Post Yachts	Southfork Boats	Vectra
Precision Weld Boats	South Shore Boatworks	Velocity Powerboats
Progression Boats	Spectre	Vintage Marine Weaver
Proline Boats	Spencer Boatworks	Boat Works
Rayson Craft Boats	Stan-Craft	Weld-Craft
RC Fabrication	Stanley Boats	Wellcraft
Regal Boats	Starcraft Marine	Wesmac Whiskey Creek
Regulator	Stingray Boats	Marine
Rinker	Storm Hawk Boats	Willie Boats Windsor
River Hawk Boats	Sugar Sand Jet Boats	Winninghoff Welded
Rivershore Boats	Sundance	Aluminum Boats
Rosborough Boats	Sunnfjord	Wolf Manufacturing
Schooner Creek Boat	Sunsation Powerboats	Wooldridge
Works	Superboats	Wrangler
Sea-Doo	SeaSwirl Boats	Yamaha Boats
Seahawk	Sylvan Marine	Yar-Craft

Brand specific pleasure boat information can be found at the end of this book.

Bayliner	- pg 89
Maxum	- pg 92
Chris Craft	- pg 94
Four Winns	- pg 95
Pontoon	- pg 96

# Examples of Pleasure Boats



2012 Cobalt 232 WSS Wake edition



2012 Cobalt A25



Fountain 35 Lightning



1998 Eliminator 28 Daytona



Sea Ray 310 Sundancer



Bennington 2277rfsi



## ***Fishing Boats***

Fishing boats come in all different shapes and sizes. Some can be universal and others are made for specific types of fishing such as bass boats, mud boats, ocean fishing and shallow lakes and rivers. They are frequently aluminum. Outboard engines are more popular on these boats than any other type for a few reasons; less maintenance, less weight and no winterizing. These boats can have many raw water pump systems like live wells and bait tanks etc. They are also more likely to be used in multiple water bodies than other watercraft.

### **Drives used:**

Outboard	Jet
Stern drive	Direct drive
POD drive	

### **These systems could be on board:**

Live well	Raw water deck wash
Bait tank	Raw water shower
Fresh water shower	Generator
Heater	Head

### **Engine Types: (most common)**

Mercury MerCruiser I4 (3.0)  
Mercury MerCruiser V6 (4.3)  
Mercury MerCruiser V8 (5.0-8.2)  
Mercury Verado I6 FI (225hp-300hp) forced induction  
Mercury Verado I4 FI (150hp-200hp) forced induction  
Mercury Optimax Pro XS I3 DFI (115hp)  
Mercury Optimax Pro XS V6 DFI (150hp-250hp)  
Mercury Optimax V6 DFI (135hp-250hp)  
Mercury Optimax I3 DFI (75hp-125hp)  
Mercury Four I4 (50hp-150hp)  
Mercury Four I3 (25hp-40hp)  
Mercury Four I2 (8hp-20hp)  
Mercury Four 1 (2.5hp-6hp)  
Evinrude Outboards V6 (150hp-300hp)  
Evinrude Outboards V4 (115hp-130hp)  
Evinrude Outboards I2 (25hp-90hp)  
Johnson Outboards

**Brands:**

Boss Boats  
Boston Whaler Boats  
Caravelle Boats  
Champion Boats  
Charger Boats  
Concept Boats  
Crestliner Boats  
Duckworth Boats  
Fish Rite Boats  
Fisher Boats  
G3 Boats  
Grew Boats  
Lowe Boats  
Mariah Boats  
North River  
Nitro Boats  
Pioneer Boats  
Polar Kraft Boats  
Princecraft Boats

Procraft Boats  
Ranger Boats AR  
Salty Boats  
Scout Boats  
Seaswirl Boats  
Skeeter Boats  
Starcraft Boats  
Stingray Boats  
Stratos Boats  
Sun Tracker  
Tahoe Boats  
Trophy Boats  
Triton Boats  
Triumph  
Triumph Boats  
VIP Boats  
Vectra Boats  
Xpress Boats

Brand specific fishing boat information can be found at the end of this book.

Alumacraft – pg 81  
Lund – pg 83  
Ranger – pg 85  
Tracker – pg 86  
Trophy – pg 87

LAKE TAHOE EIP

## Examples of Fishing Boats



North River 19' lake boat



14' Alumacraft



28' North River hard top



Sport-Fish 31 fly bridge IPS



Fountain 38 center console TE

## Sailboats

Sailboats are vessels that are powered by the wind. They frequently have outboard motors or small inboard motors to allow the boater to get in and out of port where movement is restricted and wind may be limited. This may be a point of contention where the motor is not currently on the vessel as the presence of the motor, electric or otherwise, determines the need for an inspection, the level of decontamination, and the fee.

Sail boats come in many different sizes shapes and styles, but are recognized most easily by masts and rigging that supports the sail(s), but will not be assembled and may not be visible at the time of inspection. There are also large keels on the bottom of the boat that may retract. These keels keep the vessel stable against the wind by putting the vessels center of gravity below the waterline. Instead of, or along with keels, some vessels may have ballasts on board (MacGregor & Hunter). Sail boats are also very sleekly shaped to allow for low water resistance. This means they are rather slim or even pointy in the rear compared to other vessels. However, catamaran or trimaran styles are also common.

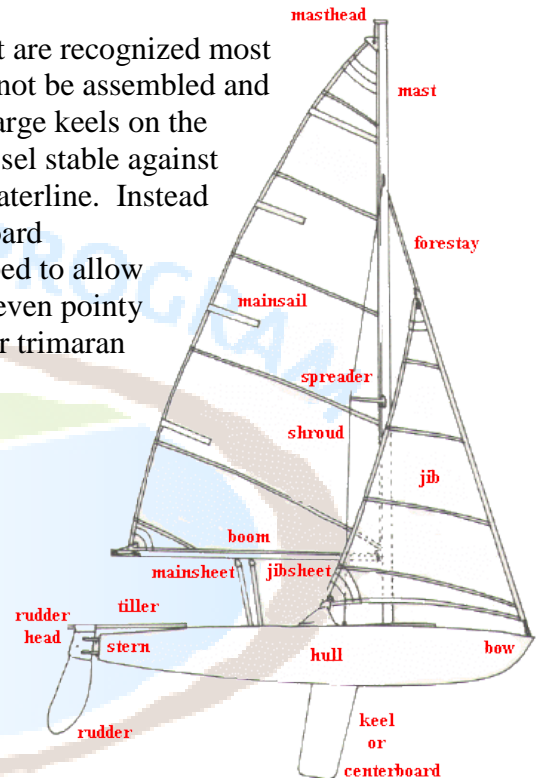

### Drives used:

None (oars)  
Electric  
Direct Drive  
Outboard

### These systems could be on board:

Head      Ballast      Raw water sink

### Engine Types:

Sail boats have a wide range of engines, mostly outboard or Direct Drive inboard engines.

### Brands:

Amel Yachts	CW Hood Yachts	German Frers
Allen Boat Co	Laurie Davidson	Hallberg-Rassy
Baltic Yachts	The Downriver	Hampton Yacht Group
Bavaria Yachtbau	Boatworks Ltd.	Hans Christian
Beneteau	Dufour Yachts	Hinckley Yachts
Benetti (Italy)	Elan Yachts	Hobie cat
Bowman Yachts	Etap Unsinkable	Ron Holland
British Hunter	Farr Yacht Design	Hood, Ted
C&C Yachts	Fairlie Yachts	Hunter Marine
C&L Boatworks	Ferretti Group (Italy)	Hylas Yachts
Cabo Rico Yachts	Flying Scot (dinghy)	Island Packet Yachts
Cascade Yachts	Gil's	Jeremy Rogers
Catalina Yachts	Catamaran (Southern California)	Juan Kouyoumdjian
Columbia Yachts		LaserPerformance

MacGregor  
Marlow Yachts  
Melges Performance  
Sailboats  
Najad Yachts  
Nauticat Yachts Oy  
Nelson Marek  
Nickels Boat Works  
Oyster Marine  
Pacific Seacraft

Rex-Meyer  
Yachts (USA)  
Sabre Yachts  
Niki Design  
Reichel/Pugh  
Rustler Yachts  
Santa Cruz Yachts  
Select Yachts  
Sensei Yachts  
Shipman Carbon Yachts

Sparkman & Stephens  
Southerly Yachts  
Swan  
Tartan Yachts  
Tecnomar (Italy)  
VPLP  
WindPearl Yachts  
Wally Yachts  
X-Yachts

Brand specific fishing boat information  
can be found at the end of this book.

Grenada – pg 98  
Hobie Cat – pg 99  
MacGregor – pg 100

### Examples of Sailboats:



Macgregor 26



Sierra Cloud Catamaran



Hobie Cat Wave



Valiant 40

## Wooden Boats

Until the mid 19th century most boats were made of all natural materials; primarily wood although reed, bark and animal skins were also used. By the mid 19th century, many boats had been built with iron or steel frames but still planked in wood. Pine, larch, cedar, mahogany, okoumé, iroko, Keruing, azobé and merbau are the most popular types of wood used for boats. These boats require a lot of maintenance and up keep, not making them ideal for the family fun boat. Today these boats are generally owned by boat enthusiasts because of the up keep cost. These boats are collector's items and pieces of art. The wood boat generation had all the same boat classes we have today such as runabout, performance, day cruisers etc. It was the pioneer age of pleasure boating. Today some boat manufactures still make replicas of these classic boats with modern day modifications and power plants.

### Drives used:

Direct Drive  
Outboard

### These systems could be on board:

Head                      Raw water sink

### Engine Types:

Wood boats have a wide range of engines that range from small two cylinder to large period aircraft engines.

### Brands:

Albany Boat Co.	Gilbert Boat Co.	Ontario Boat
Albright Boat & Marine	Globe Mastercraft	Penn Yan Boats
Aeolian Company	Greavette Boats	Philbrick Boat Co.
Atlas Boat Corp.	Grew Boat Co.	Port Carling Boat
Boesch Boats	Hacker Boat Co.	Ramaley Boat Works
Century Boat Co.	Hafer Craft Boat Co.	Rio
Chris Smith & Sons	Higgins, Inc.	Riva Boat Co.
Chris Craft	Hunter Boats	Robinson Seagull
Dart Boat Co.	Hutchinson Boat Works	Scott Boat Co.
Dee-Wite Lumber Co.	Lacaille Boat Co.	Sea-Lyon
Dingle Boat Works	Larson Boat Works	Shepherd Boats
Ditchburn Boats	Ludington Boat	Stan Craft Corp.
Dodge Boats by Horace	Mac-Craft Corp.	Stephens Marine
E. Dodge Boat & Plane	Mariner	Streblov Custom Boats
Dowsett Boat Co.	Mason Boat Co.	Sunflower Boat Works
Duke Boat Co.	Mayea Boat Works	Thompson
Dunphy Boat Co.	Meteor Boats	Tonka Craft Boats by
Eckfield Boat Co.	Midwest Boat Co.	Minnetonka Boat Works
Fetthall Boats	Minett Shields	Truscott
Fay Bow Boats	Morehouse Boat	Vanguard Power Boats
Fitzgerald and Lee	North Star Marine Const	Van-Craft
Gar Wood Boat Co.	Northwestern Boat	Wallace Boat Works

## Examples of Wooden Boats



1964 Riva



1964 Riva



The Thunderbird custom built in 1940, designed by John L Hacker (Hacker Craft)

## Personal Watercraft (PWC)

A personal watercraft (PWC), also called water scooter, is a recreational watercraft that the operator rides or stands on, rather than inside of, as in a boat. These have an inboard engine driving a pump jet that has a screw-shaped impeller to create thrust for propulsion and steering. They are often referred by the trademarked brand names such as Jet Ski,

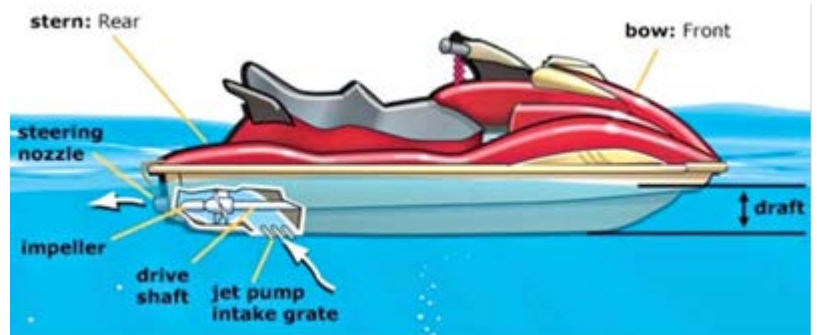

WaveRunner, or Sea-Doo. There are a wide variety of "jet boats" many of which exceed 30-40' in length. The Coast Guard defines a personal watercraft, amongst other criteria, as a jet drive boat less than 13' in length, in order to exclude from that definition, more conventional sized jet boats. Most are designed for two or three people, though four-passenger models exist.

Surfers use PWCs to get to waves and get up to speed with them; this is known as tow-in surfing. PWCs can also be used for towing water skiers on flat water. There are a number of places in which PWC operators will actually use their watercraft for jumping surf.

Modern PWCs include a lanyard attached to a dead man's switch, to turn off the vessel if the operator falls off, provided the lanyard is attached to the operator.



When inspecting a PWC have the operator remove the cover in front of the handle bars and the seat over the motor. Check for AIS and moisture.

Typically, there are two bilge plugs located on the rear of the PWC on either side of the steering nozzle. These must be opened and inspected for mud, debris, AIS and moisture.



On the bottom of the hull, is an intake grate that must be inspected for plant life, mud, or suspected AIS attachment.





**Drives used:**

Jet Drive

**Systems on board:**

PWC’s don’t normally have any type of systems however some models are equipped with bilge pumps and exterior ballast tanks.

**Engine Types:**

Normally the manufacture of the watercraft also produces the engine. PWC range from 2-4 cylinders with “muscle craft” having some type of forced induction, such as a supercharger or a turbo.

Sea Doo—ROTAX; Yamaha—Yamaha; Kawasaki—Kawasaki; Honda—Honda; Polaris—Polaris

**PWC Brands:**

Gibbs  
Honda  
Sea Doo (BRP)  
Yamaha

Kawasaki  
Polaris  
Hydro Ski  
Arctic Cat

Hydrospace  
DiMora

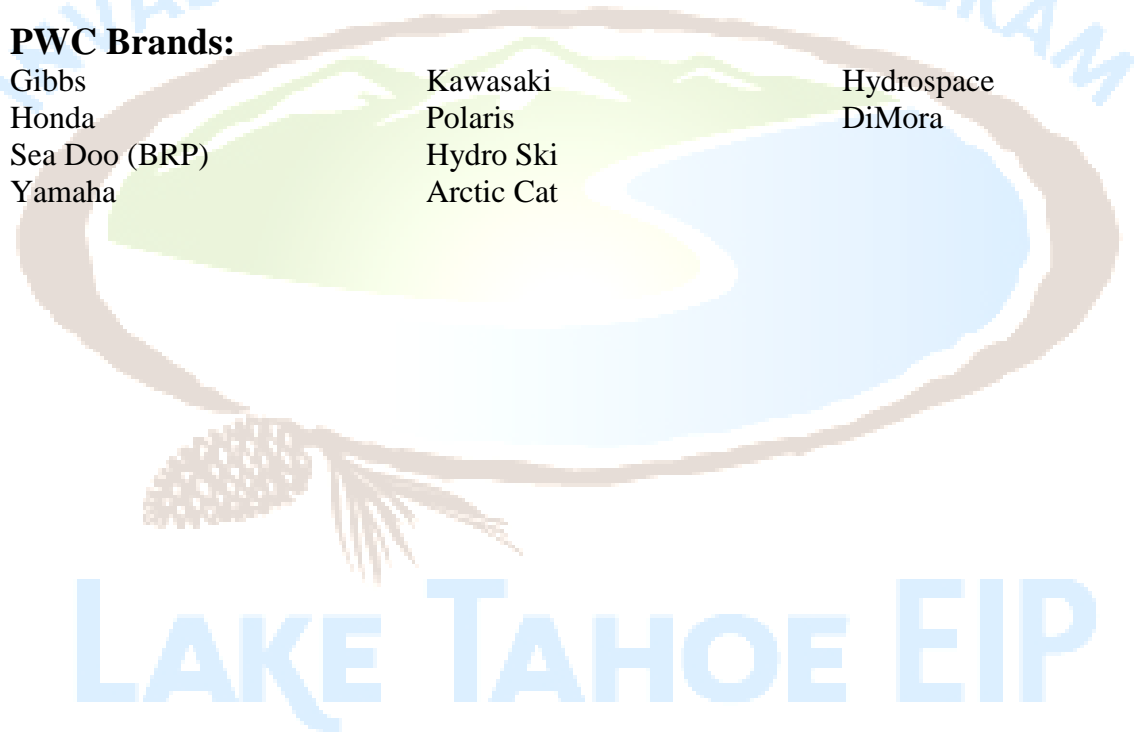

## Examples of PWC's



2008 Sea Doo RXP



2008 Sea Doo RXP



2011 Kawasaki Ultra 300X



Gibbs Quadski

## ***Inflatables and Rigid Hulled Inflatables***

Commonly used as fishing, rescue, and pleasure vessels, this category of boat is extremely vast. The best known make in this category would have to be Zodiac.

These vessels should be fully inflated in order to perform a proper inspection. Creases are difficult to inspect when it is folded. Folded inflatables also retain water and moisture for extremely long periods of time (>6 months) so owners should leave them inflated until they are completely dry.



When decontaminating these vessels, some care should be taken. The plastic glues and welds can become weakened by extended exposure to very hot water. Either lower temperatures or quicker movement over the joints should mitigate this risk.

Here is a copy of the result of correspondence with various manufacturers:

Vanguard, Sotar, Maraira, Sea Eagle and APEX manufacturers said that their fabrics could be exposed to 120 – 140 degree F. water without any damage. AIRE sent us a sample of their inflatable fabric and we tested it with 120 and 140 degree F water at low (700 psi) and high (2500 psi) pressure. However, Sea Eagle said that the pressure directed at the seams would cause damage over time. NRS Rafts stated that these temperatures would damage their fabric. They did not offer an acceptable temperature for decontamination.

LAKE TAHOE EIP

# Chapter 3: Types of Marine Engines

Very similar to automotive engines, unless you know how they work you may not be able to tell them apart. A very common engine is the GM 7.4 (454) V8, this is an engine that GMC and Chevrolet have been using for decades. If this engine is in your truck and you have a 7.4 in your boat they are similar but not the same. The 7.4 in your boat is “marinized” which means; they use brass freeze plugs on block. The camshaft and valve springs are different for the different RPM range that a boat runs in. This calls for proper jetting of the carburetor or tuned ECU's and water cooled manifolds and risers. The alternator and starter are marinized as well with a spark shield to prevent and spark from igniting gasoline vapor. The fuel system has a return line that runs from fuel pump to carb airhorn so when the diaphragm in pump should break gas is recovered into carb by a piece of tygon tubing instead of dripping into bilge.

**Carburetor:** a device for mixing vaporized fuel with air to produce a combustible or explosive mixture, as for an internal-combustion engine.

**Engine Control Unit (ECU):** a type of electronic control unit that controls a series of actuators on an internal combustion engine to ensure the optimum running. It does this by reading values from a multitude of sensors within the engine.

Carburetor



## Carbureted Two Strokes

A two-stroke engine is an internal combustion engine that completes the process cycle in one revolution of the crankshaft (an up stroke and a down stroke of the piston, compared to twice that number for a four-stroke engine). This is accomplished by using the end of the combustion stroke and the beginning of the compression stroke to perform simultaneously the intake and exhaust (or scavenging) functions.

### The 2 Stroke Cycle

Fig. 3

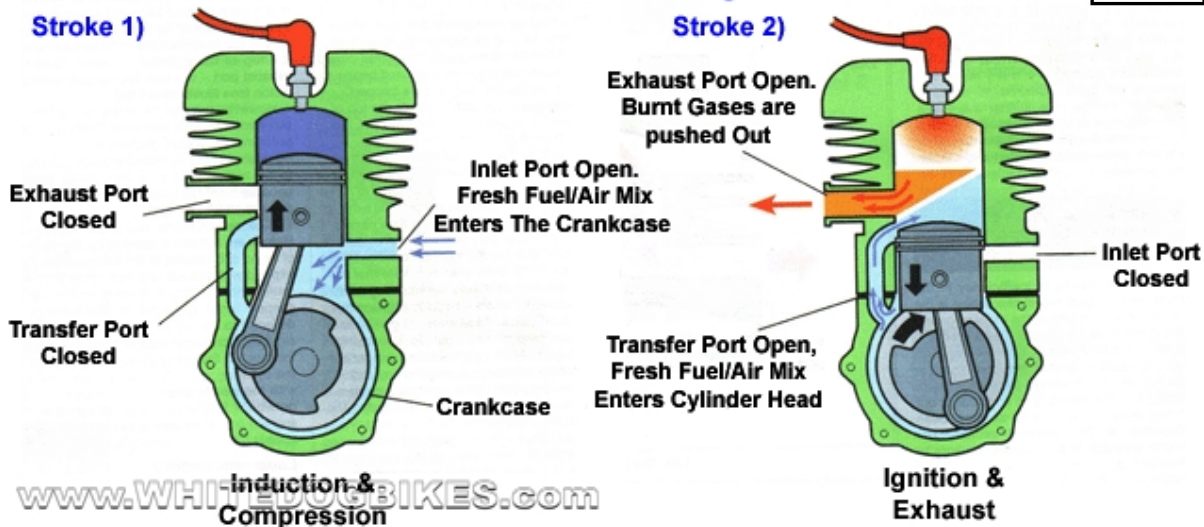

**Electronic Fuel Injection(EFI)** two stroke engines do not use a carbuerator. Instead, they use a computer to time the injection of fuel into the intake tract or cylinder port. Other than that, they work exactly the same. See page 27 under **EFI 4-Strokes** for more information on electronic fuel injection.

Two-stroke engines often provide high specific power, at least in a narrow range of rotational speeds. The functions of some or all of the valves required by a four-stroke engine are usually served in a two-stroke engine by ports that are opened and closed by the motion of the piston(s), greatly reducing the number of moving parts.

Many designs use total-loss lubrication, with the oil being burned in the combustion chamber by mixing the gasoline and oil together. This causes blue smoke and other types of exhaust pollution. This is a major reason for two-stroke engines being replaced by four-stroke engines in many applications. The picture below shows the “Blue Smoke” coming from a two stroke outboard.



**Carbureted and EFI Two Stroke engines are NOT allowed on Lake Tahoe** because of their impact on the environment. Pictured below on the left is a SeaDoo GTX, first notice the splash of 80's colors, that's your first sign. Next check to see if it has a choke, if yes then it is not allowed on Tahoe. DFI, DI, and GDI jet skis and outboards are allowed, you will see one of those three printed on the side. If not, look at the engine, if there is no carburetor it has some type of fuel injection. The first four stroke jet ski didn't come into the US until 2001.



## Two Stroke Direct Fuel Injection (DFI)

In DFI the gasoline is highly pressurized, and injected via a common rail fuel line directly into the combustion chamber of each cylinder, as opposed to conventional multi-point fuel injection that happens in the intake tract, or cylinder port.

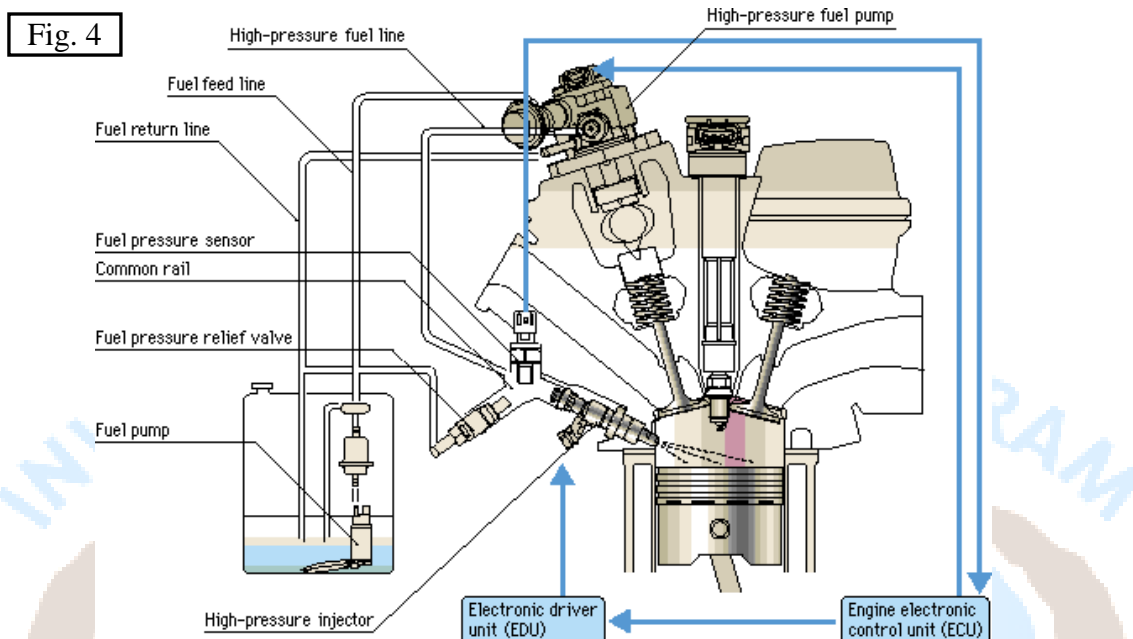

In all two-strokes, the exhaust and intake ports are both open at the same time, at the bottom of the piston stroke, for "scavenging". In conventional two-strokes, a large portion of the fuel/air mixture entering the cylinder from the crankcase through the intake ports goes directly out, unburned, through the exhaust port (blue smoke). With direct injection, only air (and usually some oil) comes from the crankcase, and fuel is not

injected until the piston rises and all ports are closed. DFI engines have an "ultra lean burn" which means the fuel is not injected at the intake stroke but rather at the latter stages of the compression stroke, so that the small amount of air-fuel mixture is optimally placed near the spark plug. This stratified charge is surrounded mostly by air, which keeps the fuel and the flame away from the cylinder walls for lowest emissions and heat losses. The combustion takes place in a toroidal (donut-shaped) cavity on the piston's surface. The cavity is displaced to one side of the piston, the side that has the fuel



injector. This technique enables the use of ultra-lean mixtures that would be impossible with carburetors or conventional fuel injection. The picture to the left, is an Evinrude E-Tec, the cleanest DI outboard in the world.

Motors that are Direct Fuel Injected commonly say DFI or DI. This is not to be confused with electronic fueled injection (EFI) engines which simply have an injection system rather than a carburetor.

Some motors do not say DFI on them, such as in the case of Evinrude, they are called E-Tec, Mercury make Optimax, and Yamaha have Vmax HPDI. The SHO is a 4 stroke. Other versions of the direct injection (Johnson, Evinrude) technology known as FICHT or FICHT Ram Injection, are also excluded from Lake Tahoe's 2 stroke ban.



Just because the engine is newer, does not mean it is DFI. Many new 2 strokes are still manufactured with carburetors.

In the newly emerging sport of MotoSurf, there are even new carbureted 2 stroke engines being manufactured by a company named MSR who make the JetSurf, a motor-powered surf board. These engines comply with all 2015 EPA Clean Air Act requirements. We are still waiting to hear if that makes it compliant for use on Lake Tahoe.



Similar systems can be seen on Oean, Lampuga, Waterwolf and WaveJet boards and Kayaks but these are currently all electric powered.

## Carbureted Four Strokes

A four-stroke engine, also known as four-cycle, is an internal combustion engine in which the piston completes four separate strokes; intake, compression, power, and exhaust during two separate revolutions of the engine's crankshaft, and one single thermodynamic cycle.

1. **INTAKE** stroke: on the intake or induction stroke of the piston, the piston descends from the top of the cylinder to the bottom of the cylinder, reducing the pressure inside the cylinder. A mixture of fuel and air, or just air in a diesel engine, is forced by atmospheric (or greater) pressure into the cylinder through the intake port. The intake valve(s) then close. The volume of air/fuel mixture that is drawn into the cylinder, relative to the volume of the cylinder is called, the volumetric efficiency of the engine.
2. **COMPRESSION** stroke: with both intake and exhaust valves closed, the piston returns to the top of the cylinder compressing the air, or fuel-air mixture into the combustion chamber of the cylinder head.
3. **POWER** stroke: this is the start of the second revolution of the engine. While the piston is close to Top Dead Center, the compressed air–fuel mixture in a gasoline engine is ignited, usually by a spark plug, or fuel is injected into the diesel engine, which ignites due to the heat generated in the air during the compression stroke. The resulting massive pressure from the combustion of the compressed fuel-air mixture forces the piston back down toward bottom dead center.
4. **EXHAUST** stroke: during the exhaust stroke, the piston once again returns to top dead center while the exhaust valve is open. This action evacuates the burnt products of combustion from the cylinder by expelling the spent fuel-air mixture out through the exhaust valve(s).

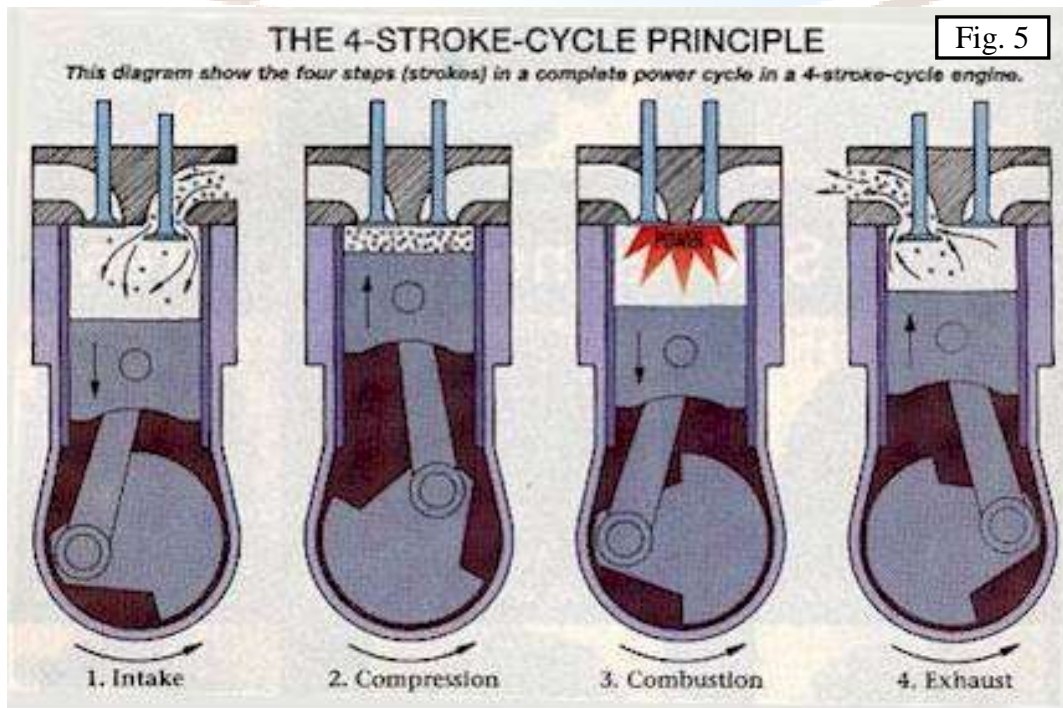



## Electronic Fuel Injection (EFI) Four Strokes

Almost all boat engines produced today have some type of electronic fuel injection. Fuel injection is a system for admitting fuel into an internal combustion engine. It has become the primary fuel delivery system used in marine engines, having almost completely replaced carburetors in the late 90s.

Operational benefits to the driver of a fuel-injected boat include smoother and more dependable engine response during quick throttle transitions, easier and more dependable engine starting, better operation at extremely high or low ambient temperatures, increased maintenance intervals and increased fuel efficiency.

An engine's air/fuel ratio must be precisely controlled under all operating conditions to achieve the desired engine performance, emissions, drivability, and fuel economy. Modern electronic fuel injection systems measure fuel very accurately, and use closed loop fuel injection quantity control based on a variety of feedback signals from an oxygen sensor (O<sub>2</sub>), a mass airflow (MAF) or manifold absolute pressure (MAP) sensor, a throttle position sensor (TPS), and at least one sensor on the crankshaft and/or camshaft(s) to monitor the engine's rotational position. Fuel injection systems can react rapidly to changing inputs such as sudden throttle movements, and control the amount of fuel injected to match the engine's dynamic needs across a wide range of operating conditions such as engine load, ambient air temperature, engine temperature, fuel octane level, and atmospheric pressure.

Fig. 6

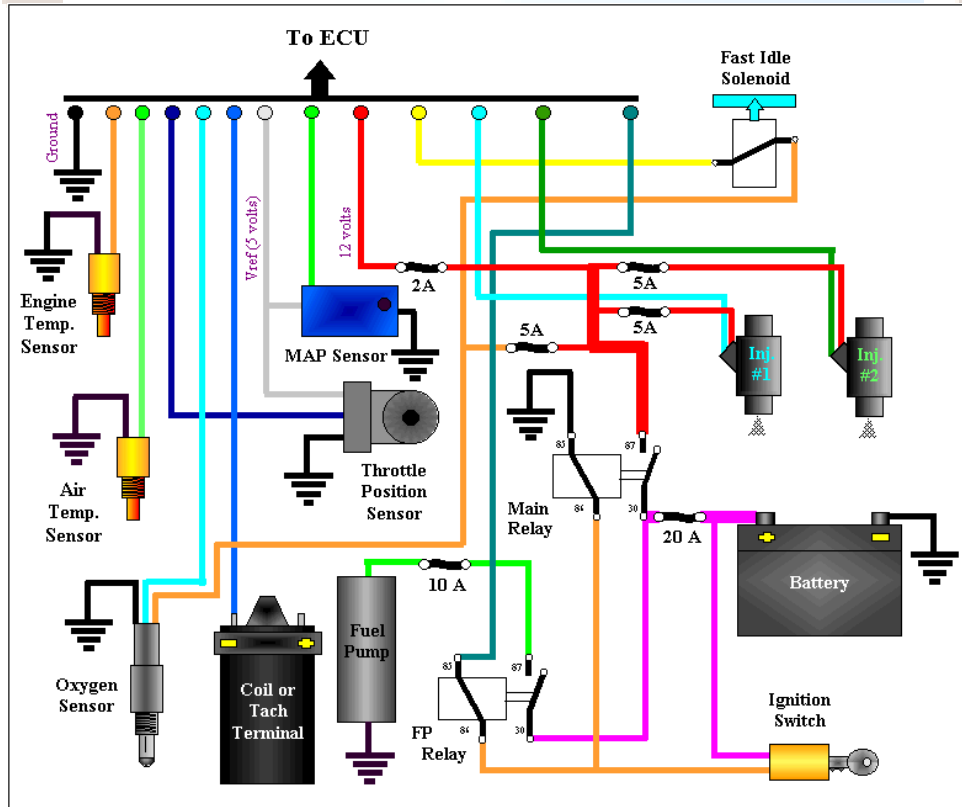

# Chapter 4: Cooling Systems

There are many demands on a cooling system. One key requirement is that an engine fails if just one part overheats. Therefore, it is vital that the cooling system keeps all of the parts at suitably low temperatures. Liquid cooled engines are able to vary the size of their passageways through the engine block so that coolant flow may be tailored to the needs of each area. Locations with either high peak temperatures (narrow islands around the combustion chamber) or high heat flow (around exhaust ports) may require generous cooling. This reduces the occurrence of hot spots, which are more difficult to avoid with air cooling. Air cooled engines may also vary their cooling capacity by using more closely spaced cooling fins in that area, but this can make their manufacture difficult and expensive.

## Open Loop Cooling

In open loop cooling systems water is circulated through the engine instead of antifreeze and that water cools the engine directly. When the boat is used in a fresh water lake this system is excellent but when a boat is used in salt water the salt water circulating inside the engine tends to shorten the life span of the engine.

Water is pulled up through the water intakes by an impeller. The water then runs through lines until it reaches the recirculating pump on the engine. It then builds more pressure runs through the block, through certain channels until it reaches the exhaust. The now hot water exits the boat through the exhaust ports.

Fig. 7

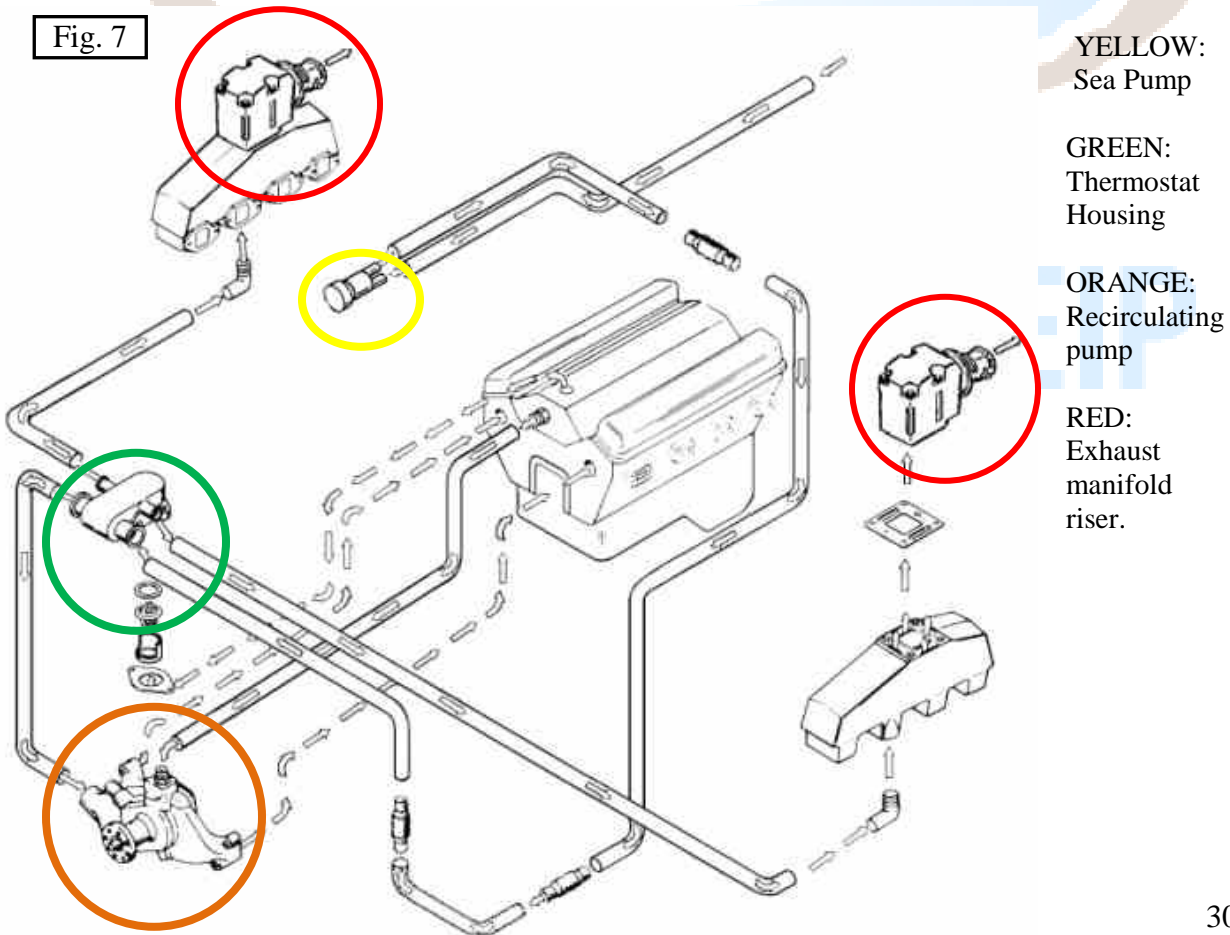

### **Decontaminating:**

Decontaminating an open loop cooling system is done by flushing hot water wherever raw water would be pumped in to cool the engine. This can be done in many ways, depending on the water intake system. The intakes differ mostly between types of propulsion. See **Drives and Propulsion** and select the drive system to find more information on decontaminating the different intake systems on open loop cooling systems.

In many cases it is good to know the water requirements of the vessel you are decontaminating. In most cases (for vessels equal to or less than 36' long) you will have no issues. However, in some watercraft, you will have to adjust for 3 major issues:

- 1: The engine(s) require more than 5 gal/min**
- 2: The intake is too large (Fake-A-Lake or for earmuffs)**
- 3: The hull is deep, leaving the engines several feet above the intakes**

#### **1: What to do when the engine requires more than 5gal/min:**

If you are using a "box" machine, you can use one of the supplied hose Y-splitters as a combiner. Use the appropriate hoses to equal the amount of water/min needed. As you will frequently NOT be using an attachment tool (as you will read later) you can also simply feed multiple hoses into the sea strainer (or flush tub if applicable), allowing you to use up to all 4 hoses on the machine for the one engine (~20gal/min). Test the output of your hoses to make sure your supply will be adequate prior to running the engine.

If you are using a mobile unit (GHO3/5000) you will have 2 on site. If both are working, fire them both up and test the output. Using both, you should be able to get ~10gal/min. If you only have one machine, or need more than 2 can supply, you will have to get inventive. Most sites have sump pumps at their disposal, and will also have 70gal flush tubs. Also, the vacuums have built in pumps that can supply about 6 gal/min and have a hose connection as well. You can use a variety of these items to obtain the flow needed by filling the flush tub with HOT water first and using the available pumps to supply that water in tandem to the output of the working machines.

#### **2: What to do if the intakes are too large for attachments:**

If the watercraft has single intakes through outdrives of some sort, it may be possible to use the flush tub to submerge the intakes. If the intakes are through-hulls, this will not be possible. Follow the instructions under #3.

#### **3: What to do if the engine is too high to pump water to:**

You should be able to tell without even trying whether the water will make it to the pumps or not. In most large boat applications, it will not work. You will have to open the sea strainer inside the engine compartment and close the sea cock that leads out to the intakes. If possible, remove the hose at the impeller as well and lower it (with water flowing into the sea strainer) to prime that length of hose. The hose may be old, or far too big to do this with.

The intakes to the sea strainer are frequently very close to the top, leaving no reserve of water for the engine. This means that if for a split second the engine takes more water than you have flowing at that exact time, it will suck air, and possibly damage the impeller. To combat this, we use our cones (small or medium), inverted into the sea strainer, with a seal around it so that we can raise the level of water above the top. To make a seal, we can use rubber gloves, duct tape (NOT on the sea strainer nut on the cone) vacuum attachments, etc...

It is common for engines to initially require much more water than it is said to need. In all cases, start with water running already into the sea strainer (make sure the bilge plug is out). Have them turn over the engine without starting several times to prime the lines and manifolds. This will also mean that the initial startup of the engine will not require such a sudden burst of water. Make sure the water level does not dip, indicating the engine is using more water than you have available. Finish the decon by opening the sea cock and decontaminating back out through the intakes.

## Closed Loop Cooling

Closed loop cooling has some of the same basic characteristics as an open loop system. This system uses coolant and raw water, doing this half coolant setup helps save important parts inside the engine that salt or brackish water corrosion can damage. Like in a car there needs to be a way to cool down the coolant. In cars a radiator is used and it's cooled by air passing by it, in boats a heat exchanger is used. The sea pump pulls raw water up and passes it through the heat exchanger. The cold water from the lake cools the coolant passing in the heat exchanger. The water then runs through the exhaust manifold risers and exits out the exhaust ports.

The coolant is pressurized by the recirculating pump, it runs all through the block, in and out certain channels through the exhaust manifolds and in to the heat exchanger.

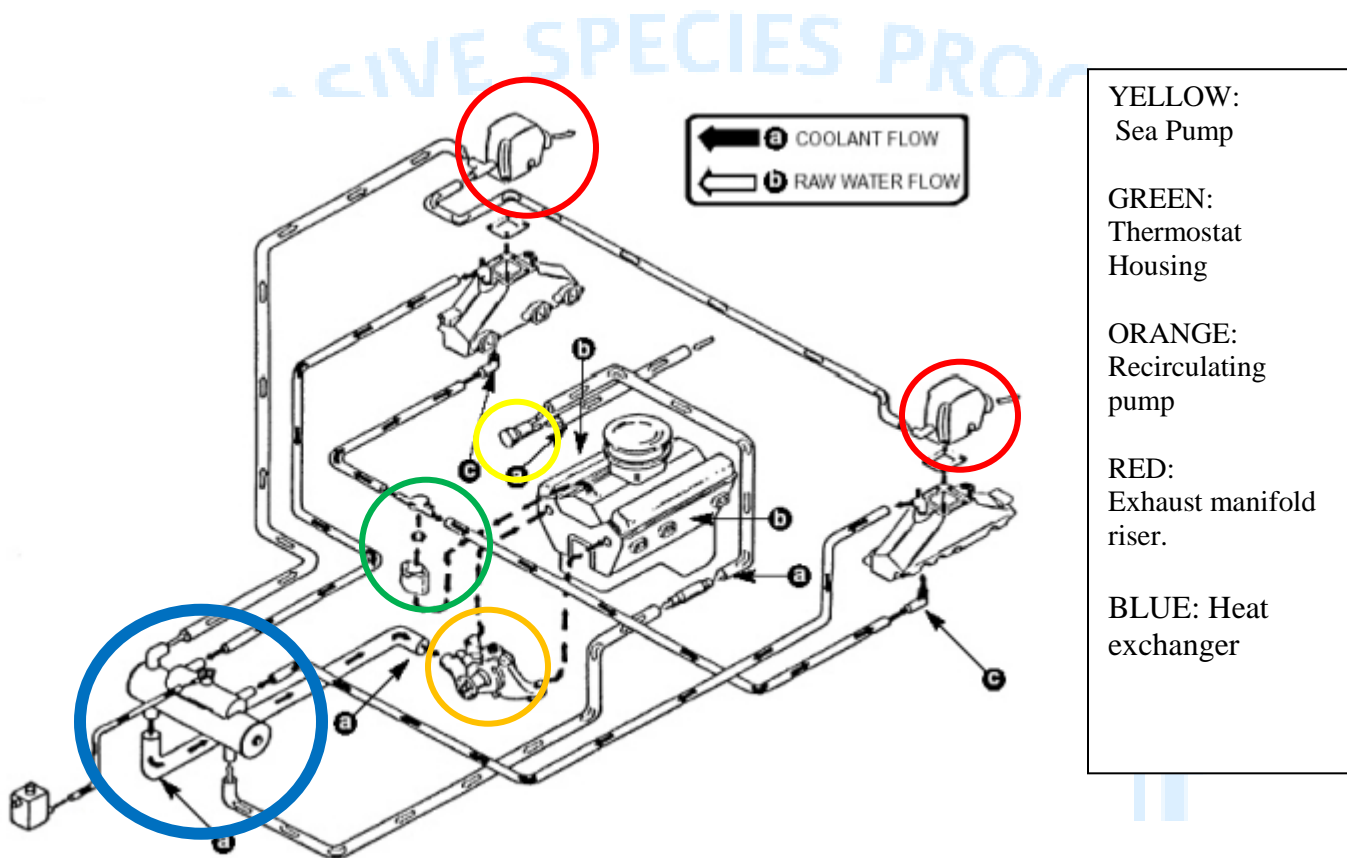

### Decontaminating:

Closed loop cooling systems can be found on many different types of watercraft. They can be decontaminated by flushing hot water wherever raw water would be pumped in to cool the coolant. Done exactly like the open loop cooling system, decontamination can be done in many ways, depending on the water intake system. The intakes differ mostly between types of propulsion. See **Drives and Propulsion** and select the drive system to find more information on decontaminating the different intake systems on closed loop cooling systems. If you are having issues, see the section under jet drives/**Decontaminating a jet drive (boats):** (pg 52) for more information on issues concerning heat exchangers.

Jet drive systems most frequently have closed cooling systems (FYI: this is because the appeal of a jet drive system is that it has no prop and can drive in shallow water where you are likely to suck up rocks, mud and debris that you would not want to send through your engine cooling system). If this is the case, see the section on decontaminating a jet drive boat (pg 52) under Drives and Propulsion.

If it does NOT have a close loop cooling system, it is not enough to supply the cooling system with water. The impeller (which will be spinning if the engine is spinning) may use bearings or wax/wire seals which rely on the water around them to lubricate or cool. We can run one hose to the cooling system(hot) and another through the jet impeller inspection cover(cold). This is a triangular screw off lid over the impeller area. However, this provides minimal water and cooling to the bearings. These systems were designed to be run in water only. There is no perfect and risk free solution to these systems. It is best to decon them without running the engine.

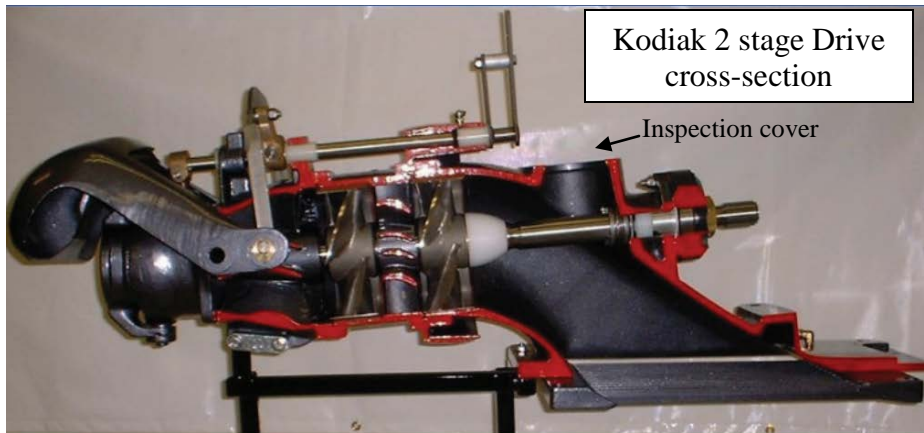

As a rule of thumb, but not always guaranteed:

Dominator Pumps: OK

Berkely Pumps: OK(from their website: berkelyjets.com)

"A Berkeley pump can be run out of the water as it has a greased thrust bearing and lubricated tailshaft bushings. The impeller does not touch the wear ring, but due to the fact that the bottom of the pump is open during trailering the boat, it is best to run water into the pump through the nozzle while running on the trailer. The only issues with running out of the water is that after about 15 to 20minutes the bowl seal can get hot from lack of cooling and cause seal damage. The packing gland may have to be re-tightened when the boat is used the next time as well."

Kodiak Pumps: NO unless using a Dry Run Kit (KM2046)

Hamilton Pumps: NO unless using a Dry Run Kit (KM2046) 770 series only

American Turbine: NO

If you decontaminate a vessel using cold water on the drive system while it is running, you will have to then decontaminate the drive system using hot water in the same manner as you would for a PWC. Decontaminate the grates and the intake area, and then back flush from the jet exit through to the intakes using hot water. Be sure that the owner knows of these risks and that we are looking into a manufacturer approved flushing method that does not involve disconnecting the drive shaft.

## Air Cooling

Air cooling is very uncommon in the marine industry and only used on small outboard engines. They are normally small one cylinder four stroke engines; no bells and whistles, not even an engine cover. Some models can have odd looking plastic or aluminum fins that help keep optimal air flow on the engine. Others are just an engine sitting on a drive shaft. This system uses no water or coolant at all.

Air Cooled Outboard "Kicker"



### **Decontaminating:**

Provided the exterior of the air cooled outboard is dry, they do not need to be decontaminated, as they do not siphon raw water. This is the same for fully electric outboards that do not siphon water.

## *Sea Pumps and Their Impellers*

Sea pumps are a simple mechanical device used for pulling in raw water to cool a marine engine. All marine engines except for a few outboards have this pump and they come in all shapes and sizes. Sea pumps have an off-set housing that a rubber impeller sits in. The pump will spin with the RPM's of the engine whether it's in an outdrive or mounted to the front of the engine. The off-set housing and the rubber impeller create a suction of water that is passed through the engine.

A sea pump is most commonly found mounted on the front of the engine with a pulley connecting it to the serpentine belt or a belt connected to the crank shaft. On Mercury Alpha drives, some OMC drives and all outboard engines the pump is located inside the upper unit of the drive system. The drive shaft in the upper unit is always spinning with the engine RPM's even when it's not in gear.

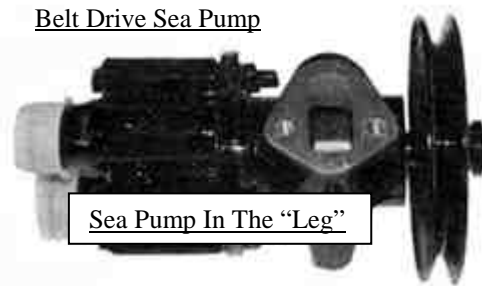

### **Decontaminating:**

Sea pumps are integral to the cooling system flush. If the pump is not taking on water, 1<sup>st</sup> check your seal on the attachment. Second, try to rev the engine a few short times to increase the suction the impeller creates. Impellers that have not been changed in a while will sometimes not create enough of a seal to perform this decon (although they will work in the water). Intake hoses can be traced in the bilge, and the decon may proceed by forcing water through the hose that leads from the outdrive, as long as the sea pump is not located in the outdrive, or "leg." When doing this, start the engine just before starting the water and stop the water just before stopping the engine.

# Chapter 5: Drives and Propulsion

## *Stern drives*

MerCruiser Outdrive



MerCruiser Outdrive



Volvo Outdrive



Many companies make either an engine or just an outdrive but only Volvo Penta and Mercury Marine make combo sets that most boat manufacturers buy. You will see OMC as well; they were bought out in the 90's by Volvo Penta.

The engine is mounted inside the boat. The drive unit is outside of the boat, attached to the transom. The engine and drive unit are joined by a torque coupler and universal joint. Moving the drive unit steers the boat acting as a rudder.

Stern Drive Boat

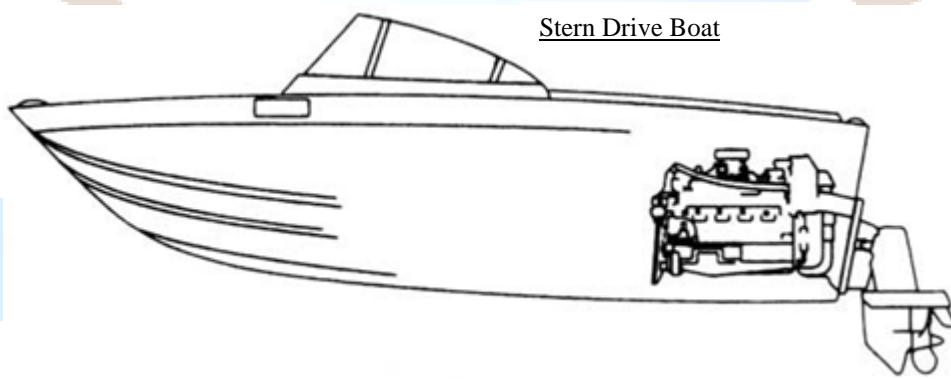

### **Stern drive in depth**

The drive unit (outdrive) resembles the bottom half of an outboard motor, and is composed of two sub-units: the upper unit contains a driveshaft that connects through the transom to the engine and transmits power to a 90-degree-angle gearbox; the lower unit bolts onto the bottom of the upper unit and contains a vertical driveshaft that transmits power from the upper unit gearbox down to another 90-degree-angle gearbox in the lower unit, which connects to the propeller shaft.



The outdrive carries power from the engine mounted inside the boat, typically mounted above the waterline, out through the transom and down to the propeller below the waterline. The outdrive can be matched with a variety of engines in the appropriate power range; upper and lower units can often be purchased separately to customize gear ratios and propeller RPM, and lower units are also available with counter-rotating gearing to provide balanced torque in dual-drive installations. The boat is steered by pivoting the outdrive, just like with an outboard, and no rudder is needed

The engine itself is usually the same as those used in true inboard systems; historically the most popular in North America were "marinised" versions of GM and Ford automotive engines. Diesel engines can be used but are less popular in the U.S.

The main disadvantages of stern drives versus straight inboards are that they are more exposed. There are hoses, rubber bellows and oil lines in the water which can be damaged. There are also more components in the water which are exposed to corrosion and AIS.

### Decontaminating A Stern Drive:



1. If there is a hose attachment on the cooling system, use this. Be careful when screwing metal threads onto plastic fittings. Make sure the sea cock on the intake is closed so that water is forced through the engine, and not out the intake. Also, when using a hose hookup, the engine will have to be started just before the water, and stopped just after the water has stopped. Otherwise, locate the water intakes on the lower unit of the out drive. These can be little holes or slats cut into the drive. On most drives they are above the bullet and have 6 to 10 inlets.

Different Intakes Require Different Attachments



2. Attach the appropriate flusher to the drive covering up the water intake holes. If the flusher has metal wires, insert the wire through the middle intake hole (Mercury Only). For all others, slide the flusher over the intakes from the rear of the drive (opposite side of the propeller).

Proper Flushing of an Outdrive



3. Start the water flow; make sure your flusher did not move due to the water pressure. Once water is flowing start the engine, make sure the impeller is pulling the water that you are feeding it. You will see the amount of water spilling out from the flusher decrease and within 30 seconds water should be exiting through the exhaust. ( If you have issues with the engine taking water see the trouble shooting section)

4. When you have finished flushing and are ready to shut down the engine be sure to turn off the engine before turning off the water. Failure to do so may result in impeller damage.

When decontaminating, always check the seating of the 'muffs' or Fake-A-Lake. Place them on snugly, using duct tape to help seal and hold them if necessary. Make sure that you notice the water over flow before the engine is started so you can more easily recognize when the engine is taking water before it comes out the exhaust. Stop and re-seat if needed. Keep an eye to make sure it does not shift during decon. You may try starting the water JUST after the engine starts to avoid the attachment slipping due to trapped water pressure. Running the engine over 1500 RPM's on a hose can result in impeller cavitation or overheating and may damage the engine.

## ***V-Drives***

The V-drive engine is mounted in the rear of the boat and the front of the engine faces aft. The engine uses 2 drive shafts and a gearbox to turn the propeller.

Connected to the rear of the engine is the transmission. The first drive shaft connects the rear of the transmission to a gearbox mounted in the centre of the boat. The second drive shaft extends from the gearbox to the rear and out the bottom of the boat to where a propeller is mounted

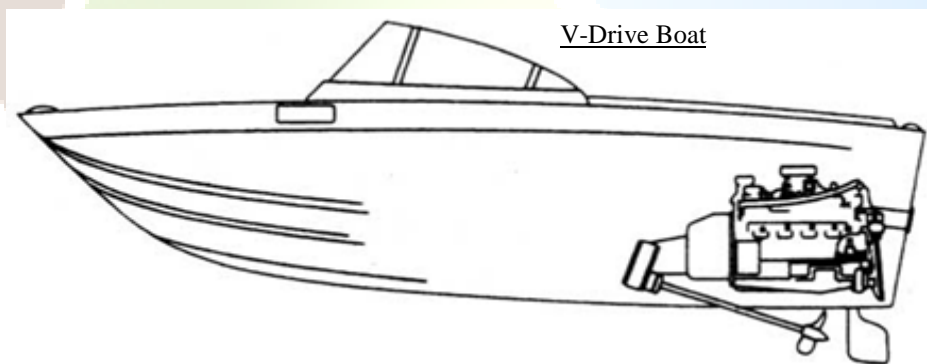

## **V-Drive in depth**

V-Drives are precision gear drives which allow inboard engines to be placed in the stern (rear) of a boat for greater safety, better handling, increased space, reduced drag, lower bow rise, shallower draft and less maintenance. The V-Drive enables the propeller to be tucked under the hull in front of the rudder instead of hanging off the stern next to the swim platform as with a stern drive. This safety feature is important on small recreational runabouts designed for the water sports enthusiast and his / her family, especially with an inexperienced captain or small children. Time tested precision ground helical gears for smooth and quiet operation. The small vertical offset allows the engine to be mounted lower in the boat resulting in a lower the center of gravity. This lower center of gravity greatly enhances boat handling, tracking and stability.

V-Drives are available in Direct Mounted and Remote Mounted models, in a wide variety of sizes each with numerous standard gear ratios and V-angles to accommodate nearly every application on runabouts, wakeboard boats, houseboats, cruisers.

## ***Direct Drives***

The engine and transmission are inside the boat. A drive shaft is connected at the rear of the transmission and is run out of the hull through a sealing unit. The propeller is connected directly to the drive shaft. A separate rudder steers the boat.

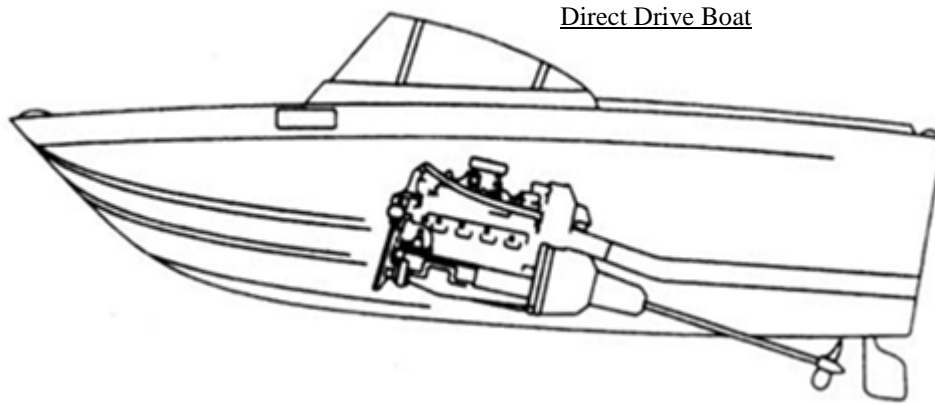

### **Decontaminating a V-drive or Direct Drive:**

1. If there is a hose attachment on the cooling system, use this. Be careful when screwing metal threads onto plastic fittings. Make sure the sea cock on the intake is closed so that water is forced through the engine, and not out the intake. Otherwise, locate the water intake on the hull of the boat (the bottom). It will be between the middle and the stern. Usually in the shape of a tear drop and made of brass.



2. Take your Fake-A-Lake (the attachment that looks like a toilet plunger) and adjust it to the right height. Cover up the water intake with the Fake-A-Lake so you have

a snug seal. Do not smash it up against the hull you may not get the water flow you'll need.



3. Turn on the water. Double check that the water pressure didn't move the Fake-A-Lake and you have a steady flow of water.

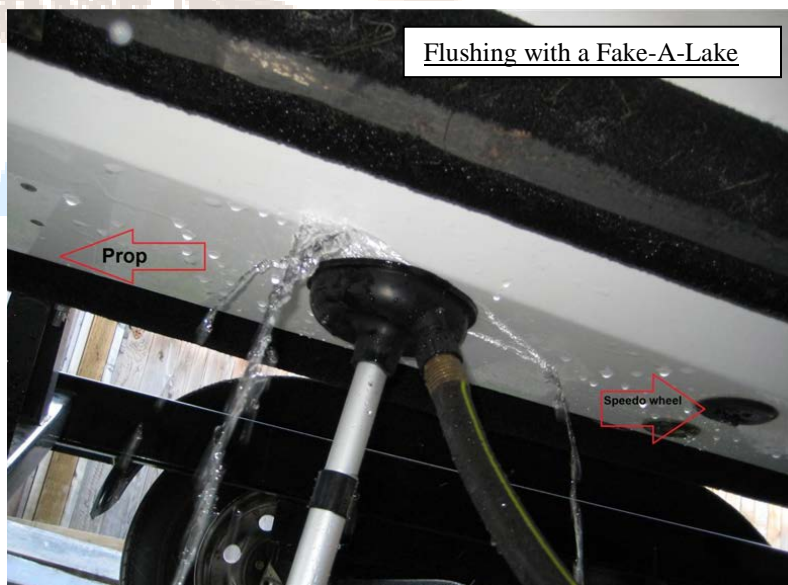

4. Start the engine, check again to make sure that the Fake-A-Lake has not moved out of position. Water will stop pouring out the sides and begin pumping through

the engine. After 10-30 seconds water will start pumping out of the exhaust. If you do not see water coming out the exhaust, but there is no overflow from the Fake-A-Lake(ie. the engine is taking all the water), you may continue past the 10 second stop time.



5. When you have finished flushing and are ready to shut down the engine be sure to turn off the engine before turning off the water. Failure to do so may result in impeller damage.

When decontaminating, always check the seating of the 'muffs' or Fake-A-Lake. Place them on snugly, using duct tape to help seal and hold them if necessary. Make sure that you notice the water over flow before the engine is started so you can more easily recognize when the engine is taking water before it comes out the exhaust. Stop and re-seat if needed. Pay attention to make sure it does not shift during decon. You may try starting the water JUST after the engine starts to avoid the attachment slipping due to trapped water pressure. Running the engine over 1500 RPM's on a hose can result in impeller cavitation or overheating and may damage the engine.

## *Outboards*

Yamaha Outboard



Honda Outboard



Mercury Jet Outboard



A self-contained unit that includes the engine, gearbox and propeller or jet drive, designed to be affixed to the outside of the transom and are the most common motorized method of propelling small watercraft. As well as providing propulsion, outboards provide steering control, as they are designed to pivot to control the direction of thrust.

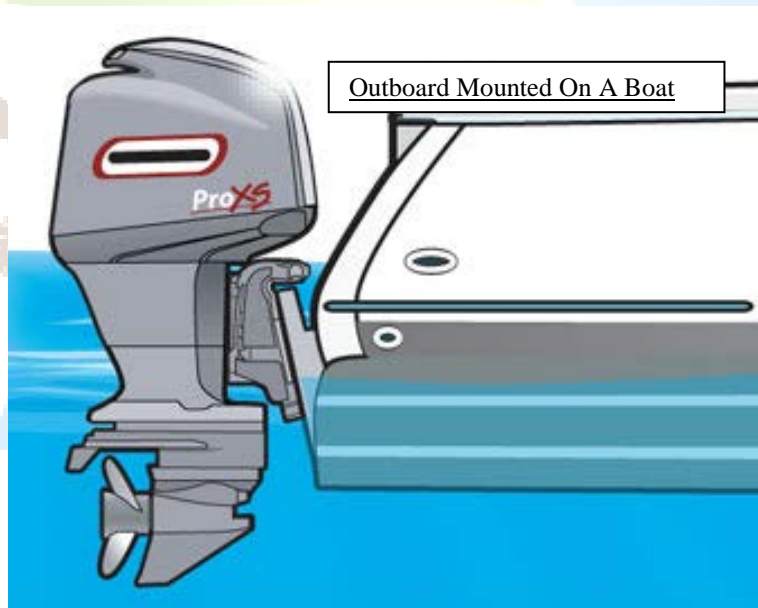

### **Outboard in depth**

Large outboards are usually bolted to the transom (or to a bracket bolted to the transom), and are linked to controls at the helm. These range from 2- 3- and 4-cylinder models generating 15 to 135 horsepower suitable for hulls up to 22', to powerful V-6 and V-8 blocks rated up to 557 hp suitable for boats upwards of 40'.

Small outboards, up to 15 horsepower or so are easily portable. They are affixed to the boat by screw clamps, and thus easily moved from boat to boat. These engines typically

use a manual pull start system, with throttle and gearshift controls mounted on the body of the engine, and a tiller for steering. The smallest of these weigh as little as 26 lbs. The fuel tanks sit inside the boat. These engines provide sufficient power to move a small dinghy at around 8 knots. This type of motor is typically used to power small craft such as dinghies, canoes, etc. To provide auxiliary power for sailboats and for trolling aboard larger craft, as small outboards are typically more efficient at trolling speeds. In this application, the motor is frequently installed on the transom alongside and connected to the primary outboard to enable helm steering.

### **Electric-Powered**

Commonly referred to as "trolling motors" or "electric outboard motors", electric outboards are used on very small craft or on small lakes where gasoline motors are prohibited and as a secondary means of propulsion on larger craft or as a thruster while fishing. Their best application is for quietness, ease of operation and zero emissions, not speed and range.

The exception to this is the Torqeedo outdrive which is electric, but also has intakes for cooling the electric motor. These will have to be flushed like any other gasoline outboard engine.



### **Jet**

Jet propulsion is available as an option on most outboard motors. Although less efficient than an open propeller, they are particularly useful in applications where the ability to operate in very shallow water is important. They also eliminate the dangers of an open propeller.



### **Decontaminating an Outboard:**

On many new outboard engines they have a hose hook up on the upper casing of the unit. This is a great system for the owner to prevent salt water corrosion inside the block, however when trying to kill AIS this hose hook-up system is not efficient. In fact, it frequently does not go through the impeller, meaning that if you run the engine while flushing this way, you may burn up the impeller. So we will use the more conventional method.



Improper Flushing Technique for Outboards

1. First locate the water intakes on the lower unit of the engine. These can be little holes or slats cut into the side. On most engines they are above the bullet and have 6 to 10 inlets.



2. Attach the appropriate flusher to the engine covering up the water intake holes. If the flusher has a metal wire, insert the wire through the middle intake hole (Mercury Only). For all others, slide the flusher over the intakes from the rear of the unit (opposite side of the propeller).

Proper Flushing of an Outboard



3. Start the water flow; make sure your flusher did not move due to the water pressure. Once water is flowing start the engine, make sure the impeller is pulling the water that you are feeding it. You will see the amount of water spilling out from the flusher decrease and within 30 seconds water should be exiting through the water exit or (pisser). If you have issues with the engine taking water see the trouble shooting section.

Outboard "Pissing"



4. When you have finished flushing and are ready to shut down the engine be sure to turn off the engine before turning off the water. Failure to do so may result in impeller damage.

\*\*When running an engine on a hose always keep your eye on the flusher because they can move due to water and vibrations. Running the engine over 1500 RPM's on a hose can result in overheating and possible damage to the engine.



## *Jet Drives*



Jet Drive System



Jet Engine and Drive System

Less common than all other configurations, a jet drive consists of an engine mounted inside the boat that is attached to a high speed pump which draws in water through an intake grate, increases its velocity, and forces it out through a directionally adjustable nozzle which is mounted outside the boat. Changing the direction of this nozzle steers the boat.

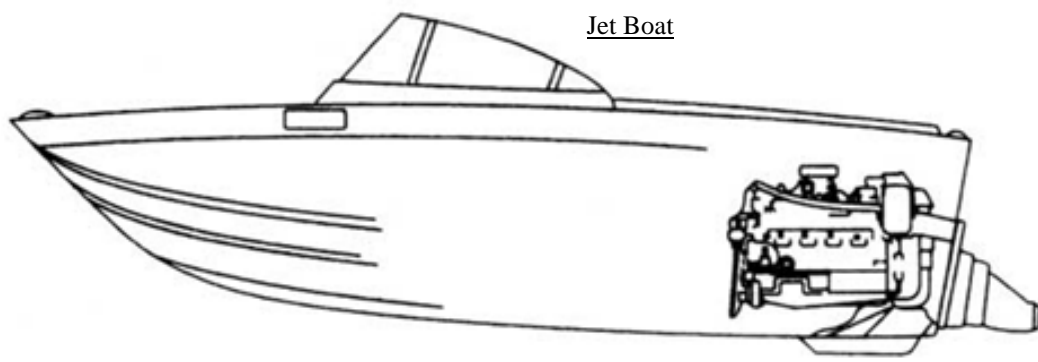

Jet Boat

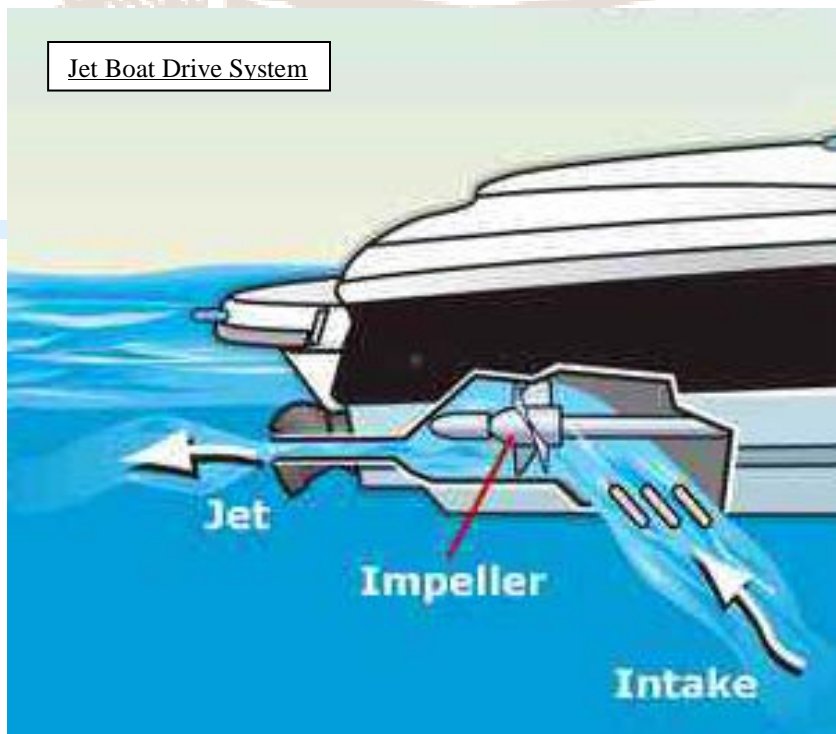

### **Decontaminating a Jet Drive (PWC's):**

Most PWC have a flush point located somewhere on the body of the watercraft. In most cases it's a female garden hose attachment.

\*\*\*When decontaminating, always start the engine first, then the water, then stop the water before the engine has stopped. Be careful not to run the engine for more than 10 seconds without water. Manufacturers contacted about this have reported various times that would be acceptable to run the engine dry; the least of which is 15 seconds. We are cautioning our inspectors to keep it to 10 seconds.

We are currently in contact with Sea Doo to verify that boats with the Mercury M2 engines (Islander and Utopia models) can be dry started for inspection. Until further notice, **DO NOT** dry start a sea Doo utilizing a Mercury engine. These systems are different than the Rotax models in that they are self-draining, and no water should remain in the exhaust.

You should also be aware that there are several possible motors for these vessels. The Merc 200 Optimax M2, and the 250 Optimax M2 are both DFI, whereas the Mercury 200 M2 is EFI and is not allowed on Lake Tahoe.

Water is not picked up in the same fashion as other watercraft. When the engine is turned on the drive shaft and impeller are moving and pumping water. A scoop located near the jet nozzle (picture an ice cream scoop) catches a flow of water and then sends it towards the engine. The water is forced through by water pressure and expelled out the exhaust. Make sure to decontaminate the intake grates as well by using the low flow adapter and running hot water over the intake area. Then run hot water backwards from the jet exit through the intakes to get the rest of the system.

Looking for PWC flush points can be easy if you know where to look. Here are some quick examples:

**Kawasaki Jet Ski:** Under front hatch, can be on left or right side.



**Kawasaki Ultra 300X Race Ski:** On the 2013 model and newer, you will find the flush point for the engine (black) on the port side of the transom. You will also find an additional flush point for the intercooler (grey). The supercharger compresses air for the engine (heating it) and then that air is cooled by raw water in the intercooler. Thus, we should also flush the intercooler when doing an engine flush. However, we will flush them separately, and ONLY run the engine when flushing the cooling system, and NOT run the engine when flushing the intercooler.

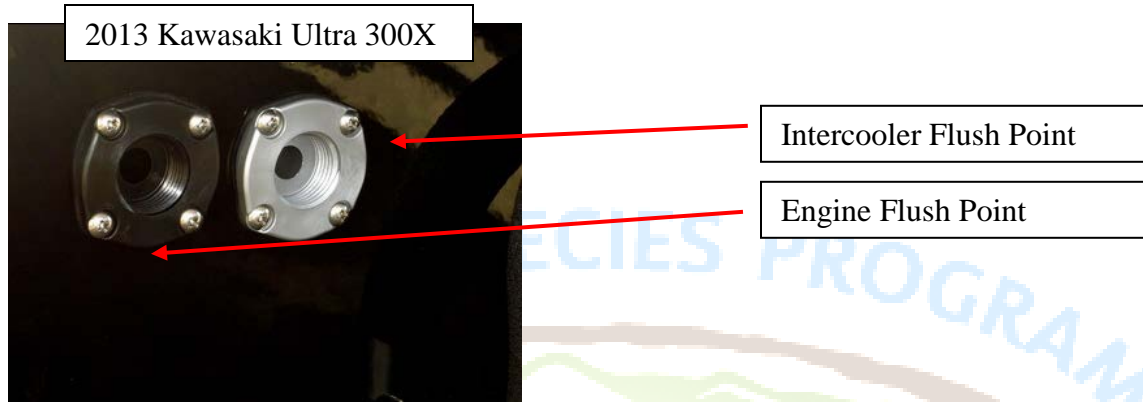

**Gibbs Quadski:** The impeller needs no water. It is always spinning when the motor is on, whether on land or water. There is an intake for the jet, but it is located on the left outside of the jet area, similar to Honda's. Unfortunately, the system will not take water without revving the engine, which is impossible to do without engaging the wheels. The Quadski has no neutral as it employs a centrifugal clutch, so revving the engine results in forward movement. Perhaps idle is enough to push water through the system, or perhaps the rear-wheel-drive unit would have to be lifted, or supported and put into ski-mode. When we have the opportunity to decontaminate one, we will devise a plan and note it here.

**Yamaha Wave Runners:** Under back seat, you need the Yamaha adaptor to fit hose.

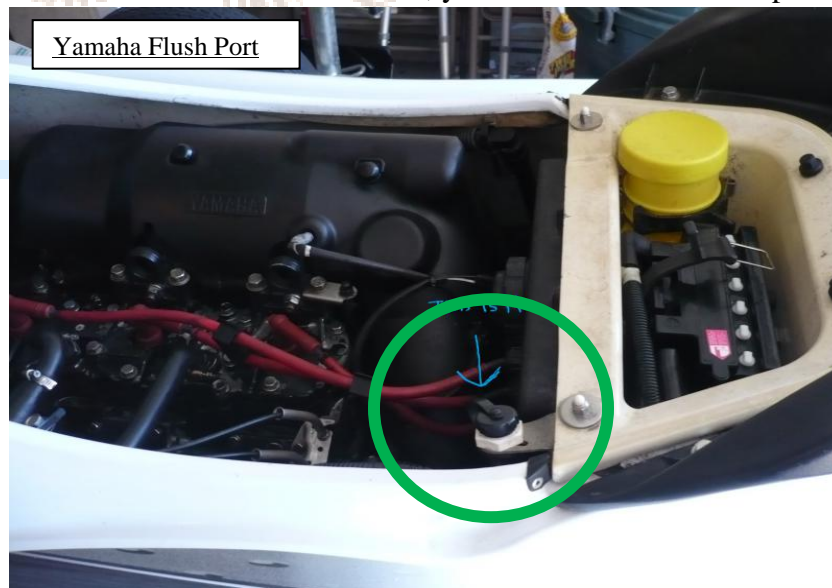

**Sea Doo:** Attached to the transom either on the left OR right of the jet nozzle.

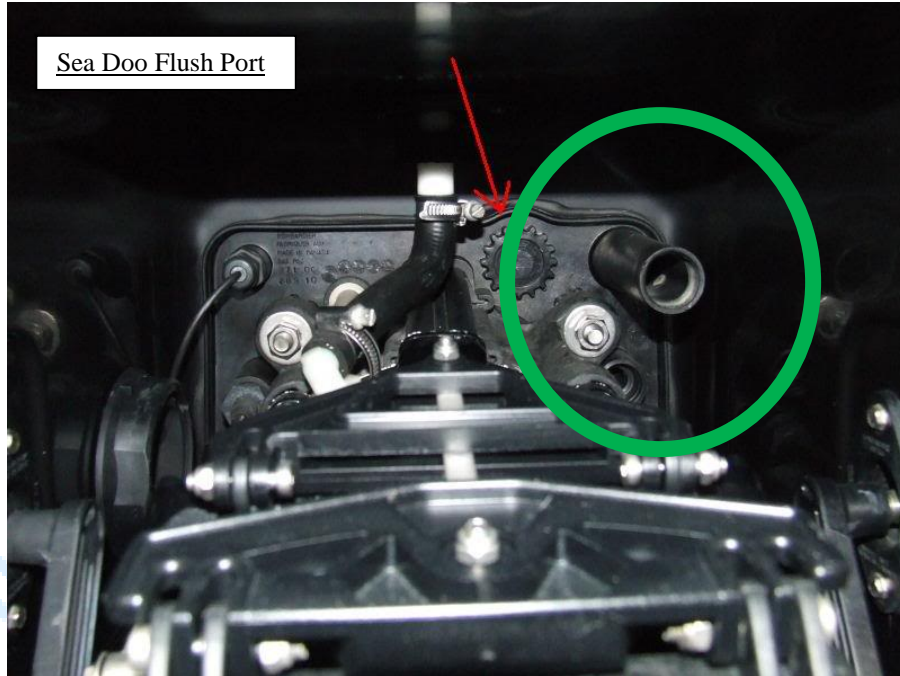

**Sea Doo:** On the 2010 and newer models they have been placed on the rear of the watercraft on the port side.



**Honda Aquatrax:** Two main placements:

1: Located in the rear to the top right of the jet nozzle. It is a 5/8" or 3/4" barb. Using a redirector or taking the male end out of the "ultimate" will allow you to use this hose attachment to flush the Honda's.

2: A hose 5/8" or 3/4" barb on the outside top left of the jet area. It usually faces in towards the jet. Using a "redirector" or gently bent "ultimate" without the other end on it should work well on this intake. You may ask the owner to put the unit in reverse to access the port easier, and then put it back towards the forward position so the deflector helps hold the hose in place. Be careful you don't pinch your fingers.

Honda Flush Port Barb

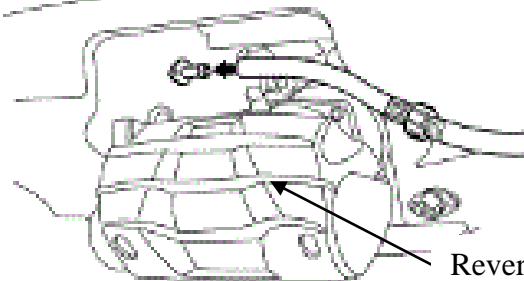

Reverse Deflector

**Polaris:** Polaris machines have a hose hookup on the "water bar" under the seat on the top of the engine. It is difficult to get to, and may need an elbow to get the hose end into it.

Polaris Flush Port

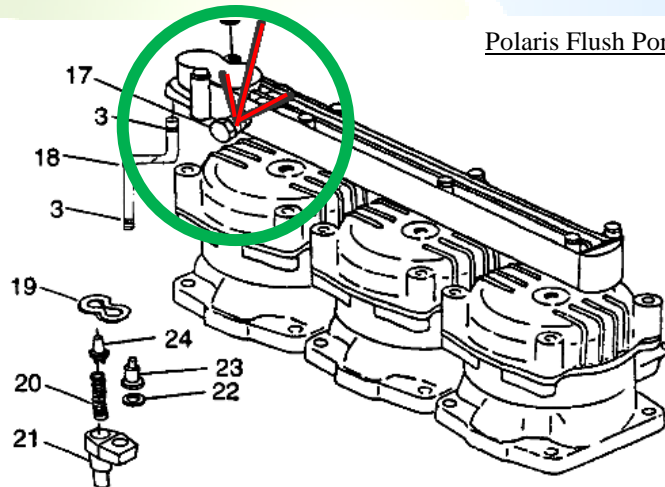



1. Locate the hose adaptor on the machine and attach your hose.



2. Start the PWC engine. After it runs for a few seconds turn on the water flow. (you must do it in that order) Water will then start coming out the exhaust and overflow lines.

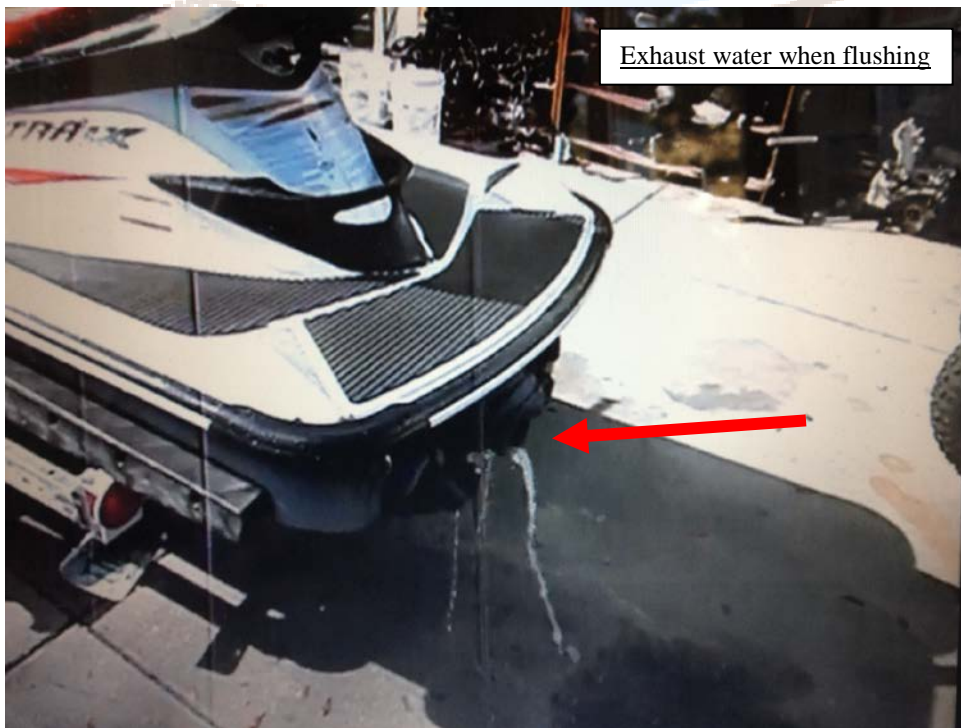

3. When you're done flushing turn the water off first. Let the machine run for a few seconds without flowing water, rev it several times to about 3000 RPM then turn it off. Disconnect the hose and replace the cap.

**FOR WAKE EDITION PWC's:**

Some wake edition PWC's include a hookup for ballast tanks. If this is the case, note that the tanks fill with the same system that propels the vessel forward. There is a hose barb on the right side of the venturi (opposite the barb for the OPAS system seen below) leading to two quick connects inside the transom area.

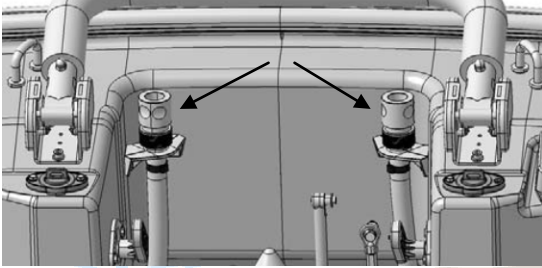

Rev the engine several times while decontaminating and open the quick connects to ensure that system is being decontaminated. Do not forget to decon the ballast tank as well.

**OPAS SYTEMS:**

Off Powered Assisted Steering systems are available on many Sea Doo's. These are fins on the rear of the watercraft that lower and turn to help steer the vehicle when there is no throttle. OPAS on the RXP's are not mobile and do not raise and lower. While running the jet ski with water attached, rev the throttle several times. If the Sea Doo is equipped, this should decontaminate the water pressure system that disables the OPAS system at speed.

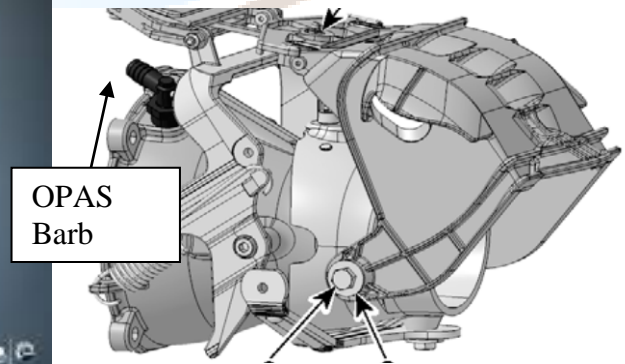

### Decontaminating a Jet Drive (Boats):

See page 31 troubleshooting box for more information on decontaminating a jet drive boat without a closed loop cooling system.

These can be hard to do, as most large jet setups like Hamilton CAN NOT be run out of water. If you find a hose attachment inside the engine compartment it is likely that you can run the raw water cooling systems without any worries, as long as you DO NOT start the engine. If a hose attachment is there here is what you do.

1. Remove the cap and attach the hose.

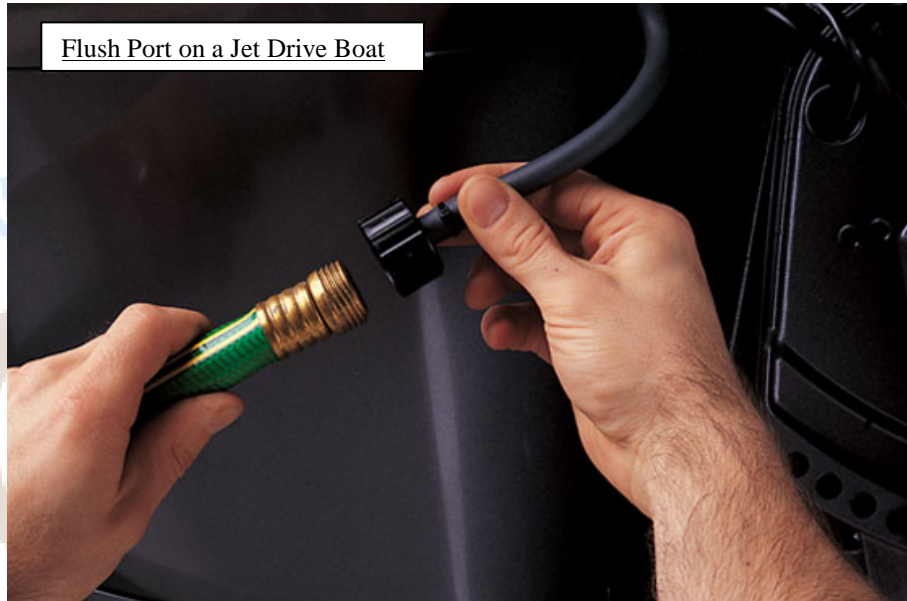

2. Turn on the engine ONLY if you have read the troubleshooting box on pg. 31 and you have been instructed to do so by the owner. Otherwise leave it off. Start the water flow after the engine has been started (if you start it). After a few seconds water should be spilling out the exhaust.



3. When you're done flushing turn the water off first. Let the engine run for a second or two without flowing water, then turn it off. Disconnect the hose and replace the cap.

\*\*\*Running the engine over 1500 RPM's on a hose can result in overheating and may damage the engine\*\*\*

**When you do not have a hose attachment:**

1. Locate the heat exchanger in the engine compartment. It's located in front of the engine or in some configurations off to either side of the engine.



2. Remove the water "in" hose. This hose, generally on the port side will be able to be traced back to the transom area. It also may have a sea strainer on the line. If green or orange fluid spills out you have the wrong hose. You are looking for water.



GM motors have a different heat exchanger, and therefore, a different inlet hose on the front right under the unit. First check the line to make sure it goes to the transom and that there is not already a flush point installed on it.

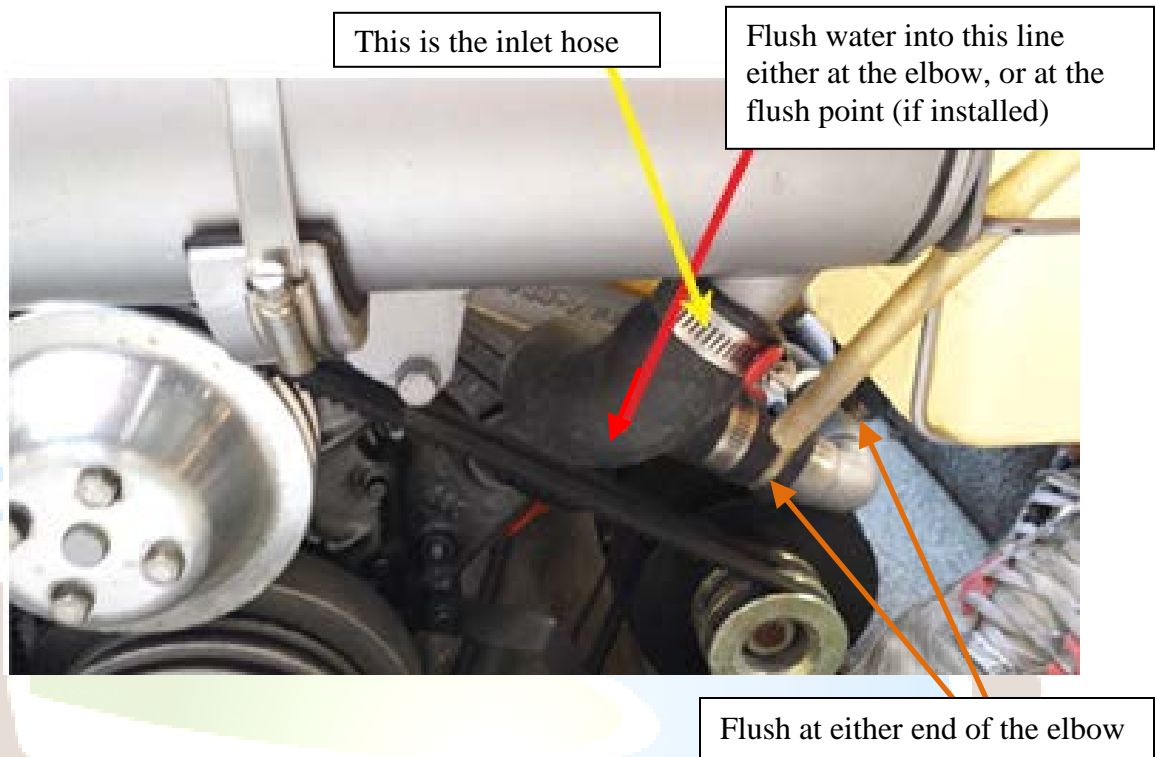

3. Connect your hose directly to the heat exchanger and start your flow of water.  
**DO NOT START THE ENGINE.**



4. Water will begin flowing through the exchanger and exhaust system. Shortly water will start flowing out of the exhaust of the boat.
5. When finished replace the hose and make sure the clamp is tight or the engine may over heat under normal operating conditions.

**\*\*\* Never start the engine during this process \*\*\***

# Chapter 6: Optional Raw-Water Systems

## *Ballast Systems*

Ballast systems are tanks on the vessel that are designed hold water in order to increase the weight in the watercraft. They are used on many watercraft; from large shipping vessels to help stabilize the ship when it is at sea, to sailboats to counteract the force and leverage of the wind on the mast (much like a Weeble), to wakeboard boats and PWCs to make a larger wake for riders towed behind. In 2014 we have begun to see ballast inspection ports on these systems, like on the 2014 Centurion Enzo 244. This system also incorporates a scoop design ballast fill, a valve design ballast empty (like MB Sports and Calabria) and an individual intake for forward ballast bags.

2014 Centurion Enzo 244  
Ballast Inspection Port



**Problems Decontaminating:** Make sure you understand the system components you are decontaminating first (see below). Often the pumps are very slow, do not cooperate, or in many cases, over-heat and shut off. In these cases, the system can be dismantled (with permission of course). Some have found that pushing a small garden hose directly into the fill ports on the bottom of the watercraft has worked well to speed up the process and make sure the pumps are picking up all the water. This is done with a piece of garden hose with a 3/8 quick connect attachment to the trigger. We call this attachment the Ballast Buster. You must always keep a close eye on whatever attachment you are using to make sure it hasn't come off. Damage to the pumps is imminent when water is not flowing.

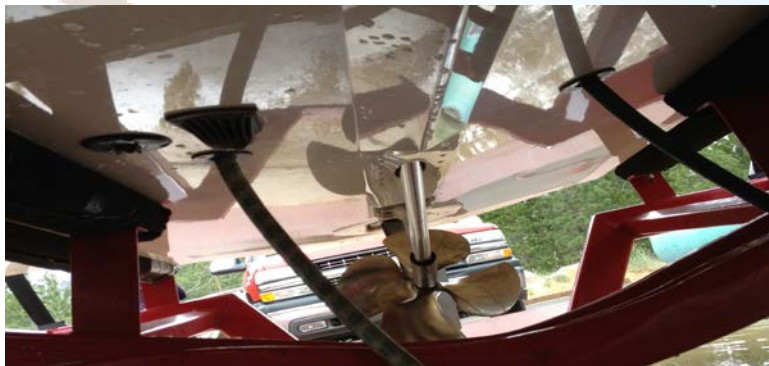

Release the hoses on the pump. You will find that some are quick-connect style plastic fittings, others are PVC and/or screwed in, while most are simply hose clamped onto barbs on the pump. Be careful not to break off barb connectors when removing hoses. Old hoses can be difficult to remove. Use the hot water from the trigger to heat up the hoses until they are pliable (about 30-45sec at least) and they will remove more easily. In many cases you may not be able to remove the hoses for one reason or another. There is very little you can do in this case except to either get the system to work correctly or to try to dismantle the system at the other end of the hose, or the tanks (assuming that the tanks are accessible). The fill and breather ports on the tanks will be on the top, and the empty will be on the bottom of one of the sides. You may have to fill through the empty ports if this is the only one you can reach. This is only done if the trigger and hose can be physically connected (hose clamp, hose connector, etc...). DO NOT simply attempt to hold the trigger in place as the pressure will build and it may spill/spit hot water out at you or others. Drain into the bilge and allow bilge to drain onto the mat. Decontaminate the bilge area again.

# Mussel Mast'R™ by Wake WorX, LLC

Vessels with the Mussel Mast'r ballast filtration system are exempt from ballast decons. However, the system up to the filter should be inspected for water or moisture. The installation of these systems has not yet been homogenized.

Inspect the filters for the appropriate security seals and dated tags. There should be security ties that prevent the filter from being removed, or the system from being opened. If they are missing, the system is NOT exempt.

They should be installed so the system is self-draining from the filter back through the intakes. Where this is not the case, or if moisture is found, this part of the system must be decontaminated. This may mean pumping hot water through the system as you would normally for 1 minute. Or, as we have requested, the filters will include a flush point on them to hook up a hose attachment.

Filters may also include a drain on the bottom of the cup to drain the water out. This is potentially contaminated water, so if it drains into the bilge, the bilge will have to be decontaminated as well.

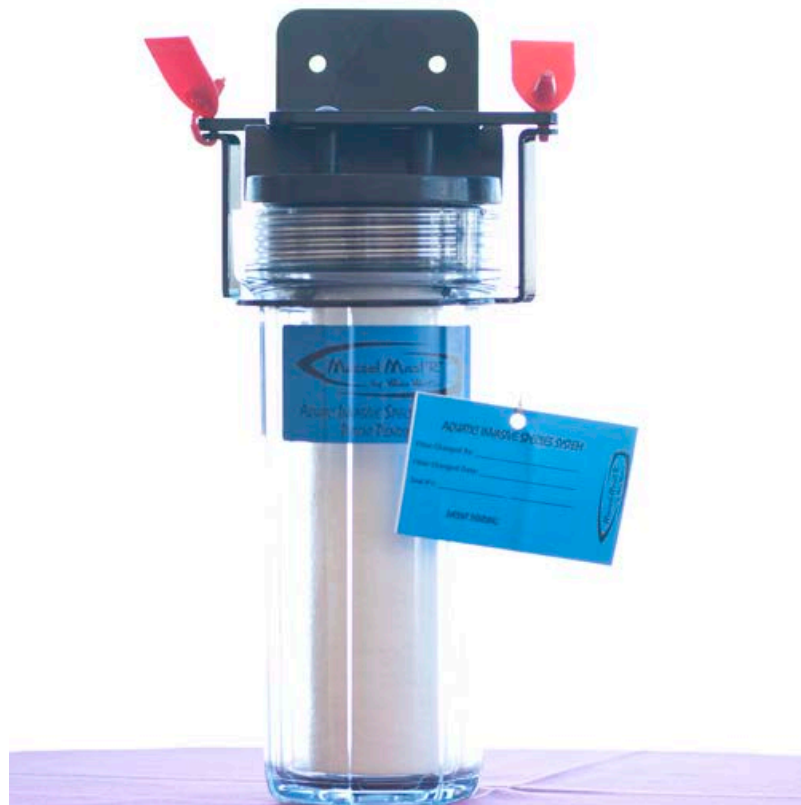

## There are 4 main ways that ballast systems are installed:

1. **Single Intake.** A single intake and pump with a distribution center (manifold) that may use electronic valves to direct the flow of water from the pump to 1 or all of the tanks or bags. These are seen on Mastercrafts, Supra's and Moomba's, for example. Note that Mastercrafts use several pumps mounted AFTER the manifold, and no valves, where Supra's and Moomba's mount a single pump BEFORE the manifold, and use valves AFTER the manifold to direct the flow of water.

**Decontaminating:** Regardless of the system, you should understand the various parts and how they work (below) to help you troubleshoot any issues you may have during a decon. A single intake system can be decontaminated by hooking the Fake-A-Lake to the single intake, and filling either all the tanks at once, or one tank at a time. Performing a decontamination on one tank at a time is recommended because it allows us to focus our energy on a single tank. This way, we can ensure it is filling properly, and it also allows that tank to drain as you are filling the next one. This limits the amount of water that is dumped onto the mat at one time, and keeps it from pooling excessively. See **Decontaminating** under #9: Ballast tanks/bags (pg. 61).

2. **Multiple Intakes.** An intake and a pump for every tank/bag on board. Each is considered a separate system. These are found on Malibu and Sanger's for example.

**Decontaminating:** Regardless of the system, you should understand the various parts and how they work (below) to help you troubleshoot any issues you may have during a decon. Multiple intake systems will have to be decontaminated one tank at a time. Make sure to have the correct intake for the tank you are trying to fill, as damage can occur to pumps that are run dry. Empty each tank as you are filling the next. See **Decontaminating** under #9: Ballast tanks/bags (pg. 61).

3. **Gravity Fill/Ram Fill.** Gravity fill tanks are usually incorporated into the hull of the watercraft as they have to be below the water line. Large gates (3"- 4") on the rear of the vessel open to fill (when boat is still), and open to empty when moving forward. These are found on Calabria's and MB Sports wake boats, as well as Hunter and MacGregor sail boats. This should not be confused with the "Gravity Ballast System" on Moomba's which actually do not utilize gravity at all, but several pumps, as stated above. Ram Fill systems, such as the 2014 Centurion Enzo 244, have large scoops under the boat to fill while moving, as well as valves on the transom to empty (like MB Sports and Calabria) and also an intake and pump system for forward ballast bags like those found on Malibu.

**Decontaminating:** Regardless of the system, you should understand the various parts and how they work (below) to help you troubleshoot any issues you may have during a decon. To decontaminate gravity fill tanks, See **Decontaminating** under #9: Ballast tanks/bags (pg. 61).

4. **Removable System.** An aftermarket system can be installed in one of the ways above in order to create or add to an existing ballast system. However, they are sometimes kept completely separate with a hose that is tossed in the water over the edge of the boat.



These systems are not wired or plumbed into the boat. These can be found on any vessel where the owner wanted the advantages of ballasts without the cost or complications of cutting holes in the boat or plumbing and wiring new lines.

**Decontaminating:** Regardless of the system, you should understand the various parts and how they work (below) to help you troubleshoot any issues you may have during a decon. Aftermarket bags can sometimes be removed and inspected for dryness, eliminating the need for a decon. If they need to be decon'd, and the system comes apart, you can decontaminate in parts. Or, to do it as a system, the pump should be placed in a bucket of water that is constantly filled with hot water. If bags are present, they do not need to be filled all the way. 5 gallons per bag usually suffices, and then they can be massaged to make sure the entire inside walls have been decontaminated. See **Decontaminating** under #9: Ballast tanks/bags (pg. 61)

Regardless of the system, you may encounter a mixture of the following devices on the ballast system:

1. 1/4 turn ball valve, or Sea Cock
2. Sea Strainer
3. Check Valve
4. "Anti-siphon" or "Vented" Loop
5. Manifold
6. Solenoid Valves
7. "Aerator" style pumps (Rule, Whale, Tsunami, Sumo, Shurflo)
8. "Flex Vein," "Impeller," or "Reversible Pumps" (Johnson, Jabsco)
9. Ballast Tanks and Bags
10. Through hulls (intakes, breather's, and discharge ports)

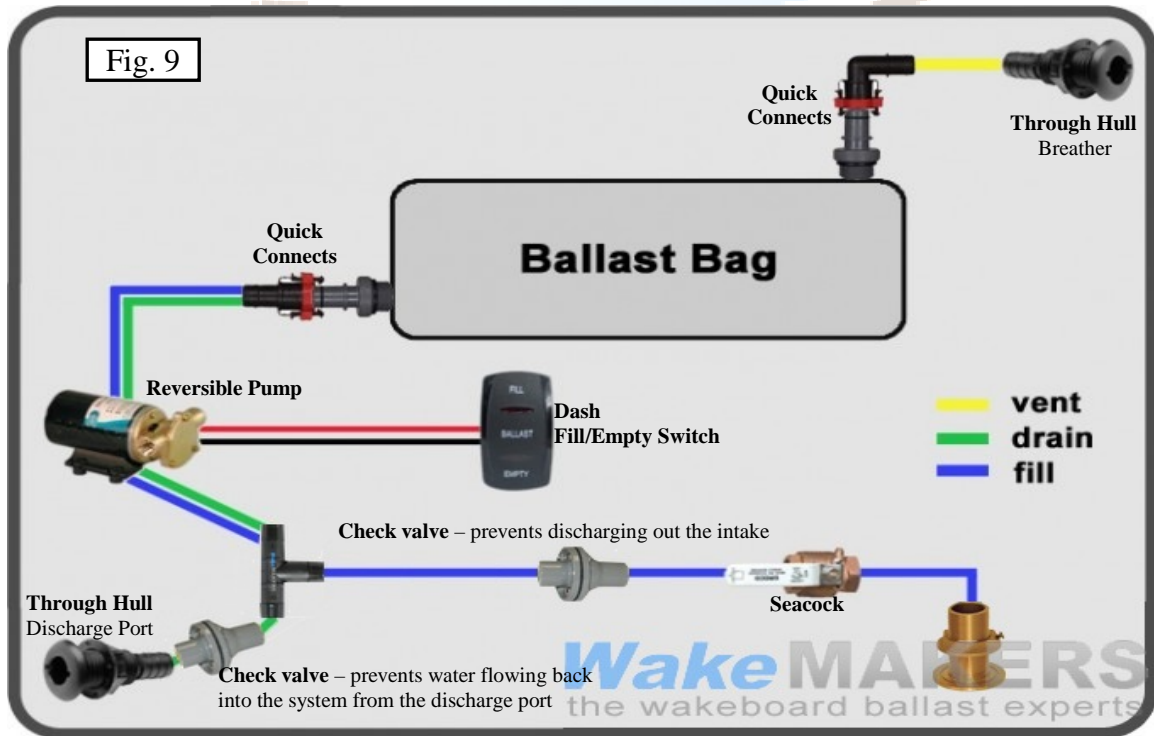

1. The Sea Cock is located very close to the through hull for that intake. It is used as an emergency valve to prevent taking on water should the rest of the system fail.

2. The sea strainer is used to remove large solids from the water prior to entering the manifold or the pumps. Debris in the water could block the electronic valves or harm the pump.



Some systems will have an intake screen. This is not a sea strainer. It can be removed to flush the ballast system or clean debris from it.

**Decontaminating:** If either is present, it should be inspected for debris, removed and cleaned prior to completing the decontamination on the rest of the ballast system.

3. Check Valves (Fig 9) are one-way valves that prevent water from passively draining from the ballast tanks/bags.

**Decontaminating:** If these systems are present, you can not force water in the opposite direction than intended. Damage to the valve or the hoses may occur.



4. Vented Loops are put in place for similar reasons as the check valves. They allow water to be pumped through, but when the pump is stopped, air seeps in and prevents a siphon from being formed. This will keep ballast tanks/bags from passively filling, or passively draining when the vessel is in motion.

**NOTE:** When tracing lines for ballast pumps check for a filter. These filters are made of plastic and can melt. If the boat has them do not let the water temperatures exceed 150°F.

**Decontaminating:** The higher these are mounted, the more air is let into the system, and the harder it may be to push that air through when decontaminating. Holding a finger over the valve will prevent it from letting any more air into the system so you can perform multiple tries if needed.

5. Manifolds are devices that separate a single source of water from a single through hull and direct it toward each of the ballast tanks. Essentially, it is a splitter.

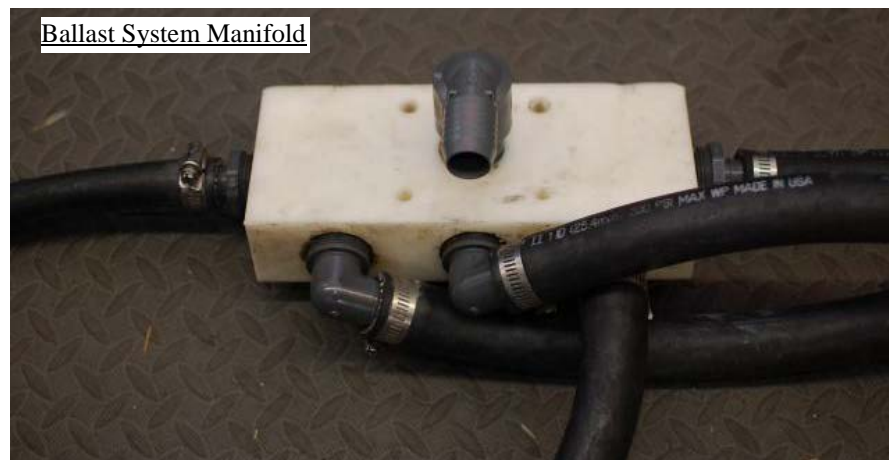

**Decontaminating:** Some provide places for either hose hookup or additional bags/tanks to be added. You may use this to hook into the system provided you have verified that the bags/tanks have vents, that the sea cock is closed, and that all the other valves to the ballasts (if present) are open. Start the pumps FIRST, but only by a fraction of a second, as you will not be able to force water through when the reversible pumps are not running.

6. Depending on the pumps used (explained later) you may find solenoid valves after the manifold. This is common on the Moomba's and the Supra's prior to 2008. The system they used was designed for sprinkler systems, and is notorious for failure and slow operation.

The valves are electronically controlled. They were designed to maintain pressure in the line so that pop-up sprinkler heads would stay risen.

**Decontaminating:** Unfortunately, should we be unable to supply significant pressure to the system, the valves will not open, and the ballasts will not fill. The single aerator pump on these systems (as you will read later) is incapable of producing much additional pressure to help.

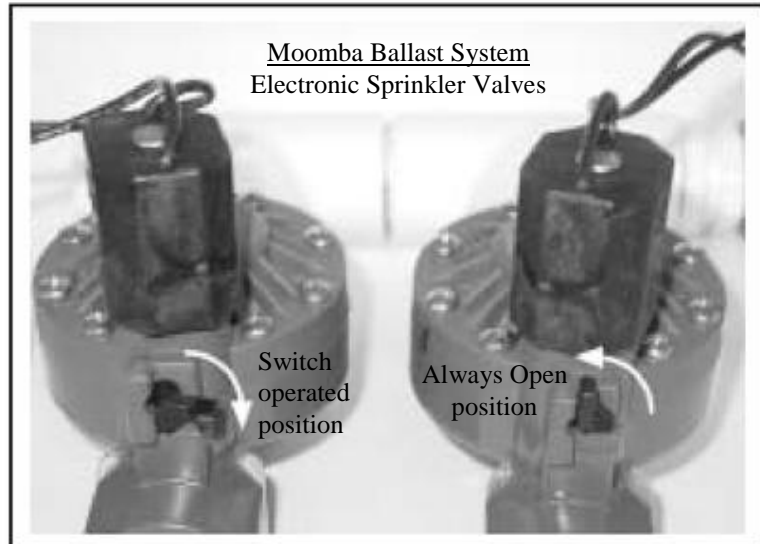

The valves usually have a manual override on them that can be switched up so that the valve remains open. However, they restrict the flow from the pump, and cause the ballasts to fill very slowly (10-15 min each). You would usually be better off disconnecting hoses right away to decontaminate the system in parts.

7. "Aerator" style pumps are smaller, and usually plastic. Common names are Rule, Whale, Tsunami, Sumo, and Shurflo Piranha. The pumps employ a small plastic fin on a motor shaft that turns at high speed (like in a fish tank filter).

Only certain ballast / bilge / livewell / and wash pumps are rated to the temperatures we are using. Jabsco pumps are rated to 180°F (black metal with silver tag), but Shurflo pumps (blue and white plastic) such as the Piranha, Pro Baitmaster, Bait Sentry, Blaster, Xtreme, and Aquaking are only rated to 130°F, and Shurflo only recommends up to 110°F. Rule pumps (red/blue and white) are only rated to 125°F. **Anytime you are decontaminating these systems, make sure the owner has this information.** No damage from heat has occurred yet to these pumps, but the pumps may turn off temporarily due to excessive heat/use, and warranties may be voided, it may decrease the life of their pump, or render it inoperable.

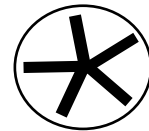

Centrifugal Pump Fins



Aerator or Centrifugal Pump

### Decontaminating:

- A. Because the fin does not flex against the sides of the pump housing (like impeller pumps) water can flow freely through them whether the pump is on or off. This means they require some sort of check valve or vented loop.
- B. These pumps create NO suction power and are NOT self-priming. This means that they must be primed after trailering, as they cannot pump air. You will also have to ensure a very tight seal to decontaminate these.
- C. These pumps can move a lot of water, but have little ability to create pressure. This means that relatively small blockages are a big issue for these pumps.
- D. They are not reversible. This means that there must be a fill pump and an empty pump for every ballast bag/tank, as well as extra plumbing.
- E. They are quite inexpensive (\$20-\$30).
- F. They have a small Amp draw.
- G. They can run for much longer periods, and even run dry.



Reversible pump  
Impeller

8. Reversible Pumps have a pliable impeller that is wedged into the pump housing. This creates a seal, and provides this type of pump some advantages and disadvantages.

### Decontaminating:

These pumps may shut off as they are sensitive to heat from use and from the water we are using. You will have to wait while they cool down to try again.

Like other electric motors, these can be seized (either the impeller is stuck or the interior magnets are misaligned). First check that the wires are properly connected. Then you can attempt to turn the pump on while tapping it and shaking it. Also, forcing water through it at pressure for a second will turn the impeller, after which, the pump may start to work.



Reversible Pump

- A. The pump acts as its own check valve due to the impeller creating a seal. No additional check valves are necessary.
- B. Because of the seal the impeller makes, it can pump air and create suction, or self prime. This means it can be mounted nearly anywhere and still create a flow of water. This makes it much easier for use on decontaminations.
- C. It can create pressure, also due to the impeller's seal. This allows it to push air bubbles and debris through the system, rather than clogging.

D. Because it is reversible, less plumbing and only one pump are necessary per system, as it can both fill and empty the ballast. In some cases it is through the same through hull as it sucks in. In some cases, as in Fig 9 , a check valve allows the water to escape through the side of the hull so the operator knows when the tank is empty.

E. This pump uses more amperage.

F. This style of pump can not be run dry, and if run for too long, it can overheat due to the friction from the fins of the impeller. Most pumps have a temperature override to shut it down if it gets too hot. This makes it slightly more difficult for using with hot water in a decon, as they frequently shut off for several minutes to cool.

G. These pumps are much more expensive. Although you need half as many of them because they can do the job of 2 “aeration” pumps, they are around 7 times the price (\$150 - \$200).

Newer Ballast systems sometimes operate the ballast fill and empty cycles based on a certain time. As we cannot provide the volume of water that would be pumped if in a lake, the process is slower, and therefore, the ballast systems sometimes turn off prior to actually being filled. Simply continue to press the fill button until you see water come out the overflow. The same may occur when emptying. You may have to hit the empty switch several times to recover all of your water.

9. A ballast tank is a compartment within a boat, ship or other floating structure that holds water. Ballast water taken into a tank from one body of water and discharged into another body of water can introduce viable aquatic invasive species that can cause environmental and economic damage. The introduction of zebra mussels in the Great Lakes is an example of this damage.

The Diagram to the right shows the cross section of a boat with two water ballast tanks. The placement of the drains of this particular tank does not allow all the water to be drained when the drain pump is activated. Manufacturers have reported that on average, two gallons of water remain after draining each tank.

Because these tanks are impossible to fully drain, they have been used in another water body, they must be decontaminated prior to being used on any other water.

Ballast tanks or bags come in a variety of materials and sizes. Most wakeboard boat manufacturers have installed factory ballasts tanks which can be hidden by upholstery or carpeting, or even be built into the hull itself. Sometimes the manufacturer will install bag systems as well. If even more weight is needed, operators may use add-on ballast bag systems to augment the stock system (examples to the left). Bags can be hidden under ski equipment or coolers and also kept

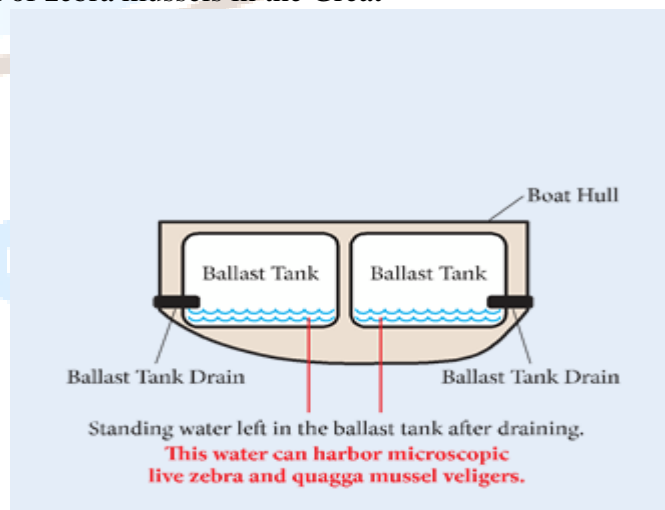

inside the tow vehicle. Make sure to ask and check thoroughly for these systems, as they may not be integrated into the vessel design, and indicators discussed below will not be present.



The first indicator of ballast systems are the through hulls on the side of the vessel (often in groups of 3 or 4) and switches on the dash that say fill or empty. Check here first if you suspect ballast tanks or bags. Multiple pumps and intakes in the bilge(s) also indicate the presence of a ballast system. Look for all the parts of the ballast system listed earlier (1-8) to help you verify.

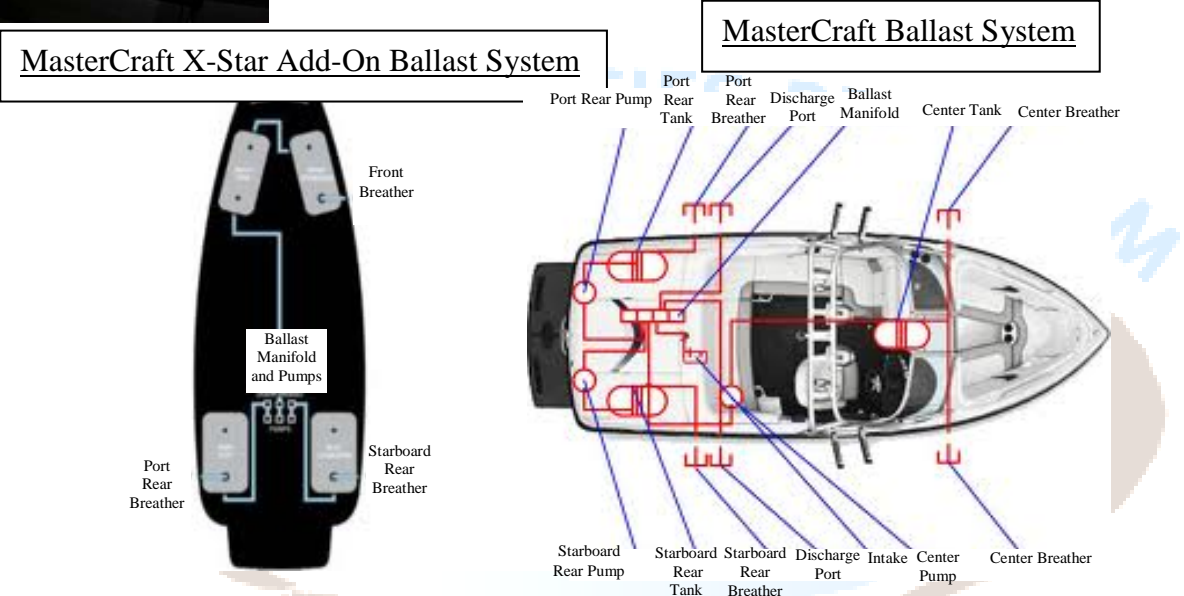

**Decontaminating:**

Make sure to locate all the ballast bags and tanks to make sure that they are all decontaminated. The likely spots are in the stern on either side of the engine, lengthwise under the rear seat, under the passenger side dash (to compensate for driver weight) in the center bilge or ski locker, and foreword under the 2 seats in the front to prevent ‘porpoising’ (sinking and popping).

Decontaminating ballast bags or PWC tanks can sometimes be done separately if they can be removed, such as in add-on systems. If the rest of the hoses are dry, you will not have to run the pumps, just decontaminate the bags themselves. When decontaminating bags, they do not have to be filled all the way. Usually 5 gallons per bag will suffice, at which point the bag can be massaged to ensure that all inside walls have been decontaminated.

## MacGregor Water Ballast System

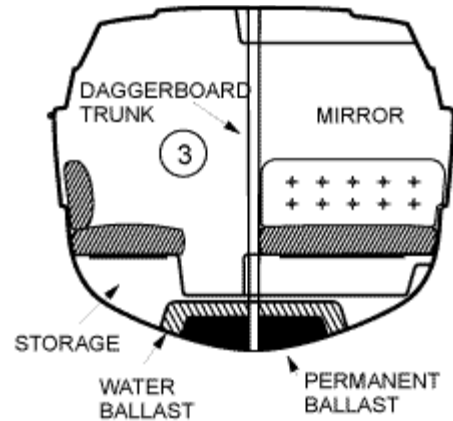
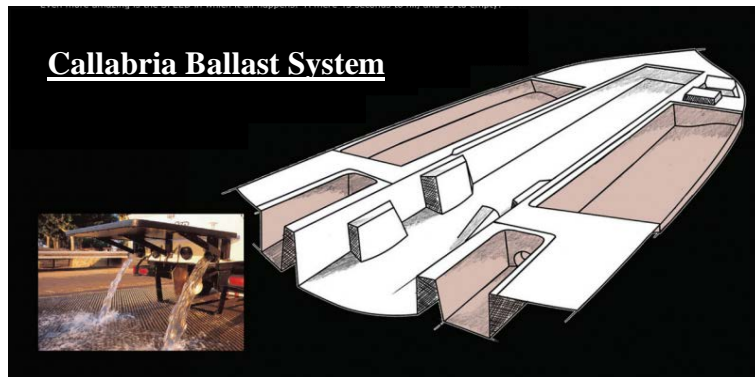

Gravity fill systems (some examples above) use large gates at the rear of the vessel to fill water into a ballast system incorporated into the hull of the vessel. Essentially, with the gates open, the vessel sinks until the tanks are filled.

Gravity fill systems can be easily filled through the large rear gates until they begin to pour out. Some employees have found that this is sometimes easier to do with a long hose on the end of the trigger. Some fill using this device through the fill ports on the transom, others through the breather ports on the side of the vessel. Some, like



MacGregor's, will have ports on the inside of the vessel (left). Some, like MB Sports, will also have fill/empty pumps in addition.

Another helpful hint is to use the small cones as a restriction in the fill ports for the ballast tanks (pointy end in the fill port). Fill through the small hole in the cone (feel free to cut the hole out if it hasn't already been done). This allows the tanks to fill more, if not all

the way. If at this point, they are not yet full, the rest of the filling process can be completed through the breathers, as long as there are multiples, or it is large enough not to create a seal around your attachment. If there is only one breather and it is tight on the redirector or hose, you will have to fill in spurts so the pressure does not increase in the tank.

Old MB Sports boats have a gravity fill ballast system, but it is much smaller than those we see today. The small fill ports are on the bottom of the vessel and partially covered. Fill instead through the drain ports (similar to the bilge plug, only located Port and Starboard on the transom). Use a 1/2" NPT male pipe end.



10. Through hulls are used extensively on ballast systems as intakes, breathers, and discharge ports.

**Decontaminating:**

As the plumbing itself is often hidden from us, it becomes very difficult to know which through hulls go to what system. Here are some things to consider while decontaminating:

**Intakes:**

- A. Some systems have multiple intakes: 1 for each bag/tank. They must all be addressed individually. Be careful only to run the pump for the bag/tank you are filling. Make sure you have traced your hoses so you know which pump you are using. If you can not see the hoses adequately, put your hand on the pump and have the owner turn on each pump in VERY short spurts until you feel the pump turn on.
- B. Some intakes are on the rear of the vessel. Screens sometimes screw off and allow for the female hose adapter on the decon unit to screw on. Be careful whenever screwing the metal adapters to plastic threads.
- C. Sometimes one intake can service multiple bags/tanks and only have one discharge port or breather, such as in the X-Star add-on ballast system for the forward two ballasts.
- D. Systems with manifolds can be run to fill all the tanks through one intake. They may all share a discharge port. There may be several discharge ports.

Some staff have found that decontaminating is easier using either the redirector or the low flow nozzle or the ballast buster to push directly into the intakes (also see Troubleshooting box (pg 55).





### **Breathers:**

- A. The minimum that a ballast BAG needs is 1 through hull for both fill and empty (using a reversible pump). No breather is necessary because the bag expands and contracts, but they may still exist. Be VERY careful with this system as the hot water, steam, and pressure from the decon machines could rupture the bag. Check to make sure that the bag is venting out a through hull. If it is not, fill in short spurts, and remove your decon attachment from time to time to relieve the pressure.
- B. All ballast TANKS need at least one breather valve to let the air escape or enter.
- C. For systems that can fill or empty very fast (Calabria and MB Sports for example) there are usually multiple breathers to let the air escape as fast as possible. Think about which will fill faster when submerged: a small neck bottle, or a pint glass? The 2014 Centurion Enzo 244 has VERY large “Ramfill” breather ports. Shown is one option to decon these tanks. Another would be through the inspection port, or the transom drain valves (like those on Calabria’s and MB Sports).

2014 Centurion Enzo 244 “Ramfill” Breather Port



### **Discharge Ports:**

- A. Some pumps have 2 or more discharge ports per tank, sometimes on opposite sides of the vessel.
- B. Some systems discharge out the side of the hull, and others through the intake. Remove the Fake-A-Lake before flipping the empty switch so that water is not trying to escape the sealed intake.

## ***Bilge Oil Separators:***

Bilge Oil Separators are used on mostly larger vessels such as tankers and fleet ships that may have large amounts of oil accumulation. However, as it is illegal to dump oily bilge water most places, there has been a push to include smaller sizes on pleasure boats. They are simple, in that they passively filter oil out of water pumped out of the bilge before it is discharged. You may be able to see these systems, and perhaps not, such as on the Air Nautiques from 2013 and later.

In general, they will be set up like in Fig 10. Because they are a filter, they will not be able to be back flushed. As you will not always see them, you must remember to always feel for backpressure whenever back-flushing any system.

Bilge Oil Separator setup

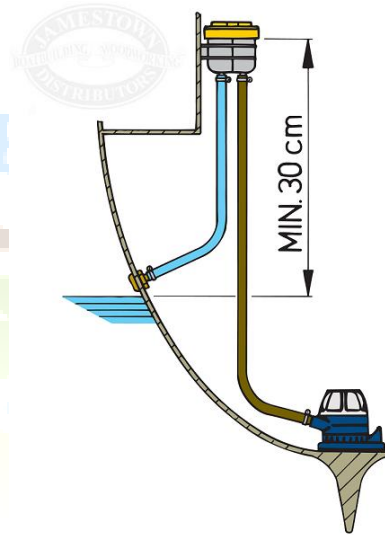

Some examples of filters are shown here:

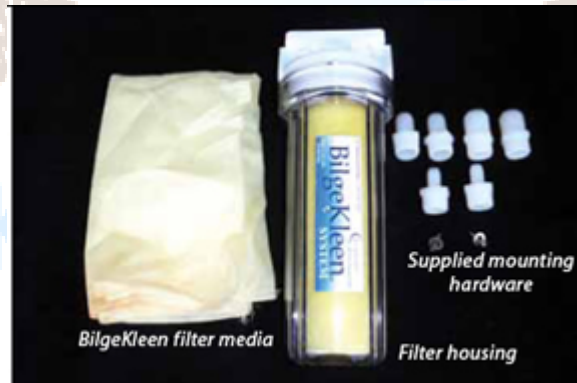

## ***Air Conditioning Units:***

Air conditioning units are used to cool the inside of the vessel. They are rarely found on vessels less than 26 feet in length. Air conditioning units are easy to identify, and quite simple to decontaminate. However, A/C systems require 120V power, and they will not turn on unless the generator is running or you have supplied shore power to the vessel.

### **Decontaminating:**

To decontaminate an air conditioning unit, we usually do so in reverse (using an A/C attachment) through the discharge port as we would otherwise have to provide shore power or also run the generator. A/C systems are almost always free flow, meaning that we can do this in reverse without hurting any parts. Note that there may be multiple discharge ports or multiple condensers. This means that we may have to decontaminate more than one system. However, in most cases, just going in one discharge port produces enough pressure to push water through all the condensers and discharge ports, as long as they share an intake. This is most easily done using the supplied air conditioner flushing tool which is small enough to fit in the air conditioner through hulls. The exit for the air conditioner is usually very small (1/4") but still must be traced to make sure back flushing is not flooding the drip tray or another system all together. Make sure you have the correct through-hull, as forcing water in others could flood or damage the boat.

You will find the following devices on an air conditioning system:

1. Intake/Sea cock
2. Sea Strainer
3. Impeller/Reversible Pump
4. Condenser
5. Discharge Port

1. Intakes/ sea cocks are usually inside the bilge. They run directly to a sea strainer, and then a pump.
2. Sea strainers are always present on A/C units to filter solids as the plumbing inside the condenser is small.

**Decontaminating:** Remove the strainer and rinse it clean of debris.

3. Pumps are almost always the impeller type. Deck showers use the same system, but usually run to the stern, where A/C units run forward to the cabin. It is important that you trace the lines so you are aware that the pump you are looking at is the A/C. Ask the owner if they have deck showers and to turn on the pump so you can feel to make sure that it is running. A/C units will not turn on unless the generator is running, or you have supplied shore power to the vessel.



**Decontaminating:** This can be decontaminated in reverse as explained below under **5: Discharge ports**. However, if the system is to be decontaminated as it runs, simply hook the water to the correct intake and turn on the AC (shore power or the generator must also be running). For multiple AC condenser units, turn them all on. For multiple intakes, do one AC condenser at a time.

4. The condenser(s) may be inside the bilge, and it may be in the cabin. They are usually white or black and on a tray to contain any condensate. There is an intake hose and a discharge hose for water that is used to cool the condenser. There is an intake fan and filter which then pumps cool air through ducting hoses throughout the vessel.

**Decontaminating:** See **4: Impeller Pumps**, above.

5. The water exits the condenser through a discharge port. Air conditioning discharge ports are usually the smallest ones on the vessel as the plumbing is quite small. There is also sometimes a port that drains the drip tray (which may also drain into the bilge or the shower drain box). It is important that you know which is which, as we decontaminate these systems in reverse. If we pump water in the wrong through-hull, we will flood the drip tray and then the cabin. Some A/C systems have multiple condensers and/or multiple discharge ports.

**Decontaminating:** Using the appropriate tool; force water through the discharge port until you see water exiting the intake port. Be careful to notice excessive push back, as this may indicate you have the wrong through-hull or there is a check valve on the system. However, as the plumbing is long and small, there will be some pressure. Do this for each discharge port unless the water comes out of all discharge ports and intakes at the same time.

LAKE TAHOE EIP

## ***Generators:***

Generators are simply gasoline engines hooked up to an electrical generator. They are usually red or white. You will rarely see these on vessels less than 26 ft. You will encounter the following systems on a marine generator:

1. Intake/sea cock
2. Sea Strainer
3. Generator
4. Exhaust/discharge

Running much like the drive engines, these generators take in water to cool the engine and discharge it with the exhaust.



Generator

### **Decontaminating:**

Decontaminate these as you would a normal inboard engine. However, there are some notable differences with the generators:

1. Generators do not use as much water
2. They are notorious for being poor at taking in water
3. Impellers heat up faster than drive engines, be careful not to run dry, or for too long

LAKE TAHOE EIP

## Cabin Heaters

### Types of heaters:

- Fan/radiator heaters use the circulating coolant from the engine to a radiator or fan. Like in a car, these systems only work if the engine is on.
- Hydronic/circulating coolant furnaces use the heat from the engine when it is running to circulate to a furnace or a fan, but also have a furnace that runs on fuel to heat the same coolant when the engine is not running. This also allows this system to heat the engine up on cold mornings, or could double as the vessels hot water heater.
- Electric Space Heaters are similar to home portable heaters, but draw too much power, and therefore will drain batteries or require the generator to be running.
- Vented Propane heaters use a propane burner and a fan.
- Pot Burners use the same fuel as the engine to provide radiation heat to small areas.
- Forced air furnaces use the same fuel as the engine and an air to air heat exchanger and blower to heat a larger area.
- Non-vented portable heaters use kerosene, white gas, or alcohol and do not use fans or exhaust.

Hydronic Heater



Forced Air Furnace



### **Decontaminating:**

The only types of heaters that need to be decontaminated are those that utilize the engine coolant (fan/radiator and Hydronic/circulating coolant heaters) and only when raw water is used as the coolant (there is no heat exchanger on the engine). Remember that there may be heaters for heating water as well, including for the deck shower, so ask and look for those as well.

They are simple to decontaminate. Simply have the operator turn the heater on after you have started a normal engine flush, and continue your engine flush as normal. **If you are unsure what type of heater is present, and if it needs to be decontaminated, simply turn it on anyway during your engine flush.**

## Sinks and showers

The plumbing on a boat is relatively simple. Most systems only have the ability to use fresh water, as oppose to raw water. This means that all the systems on the boat will use water from a tank onboard that has been filled with water from shore.

**Decontaminating:** In the rare event that the tank can be filled from raw water, you will have to hook a Fake-A-Lake up to the intake port, fill the tank to the top, wait 1 minute, and then run all the systems separately until the water has been fully discharged through the various systems (explained below).

You may see the following devices on the sink and shower system:

1. Fill/Intake
2. Sea strainer/water filter
3. Pump
4. Storage tank
5. Accumulator
6. Check Valves
7. Water Heaters
8. Pressure Valves
9. Sinks
10. Showers
11. Raw water deck shower

1. Fill/Intakes. Most vessels will not take raw water for sinks and showers. In these cases, there is a fill port for filling the tank from shore. However, in a few cases, water can be siphoned from the lake or river in order to fill the tank. In this case there will be an intake and sea cock on the bottom of the vessel.

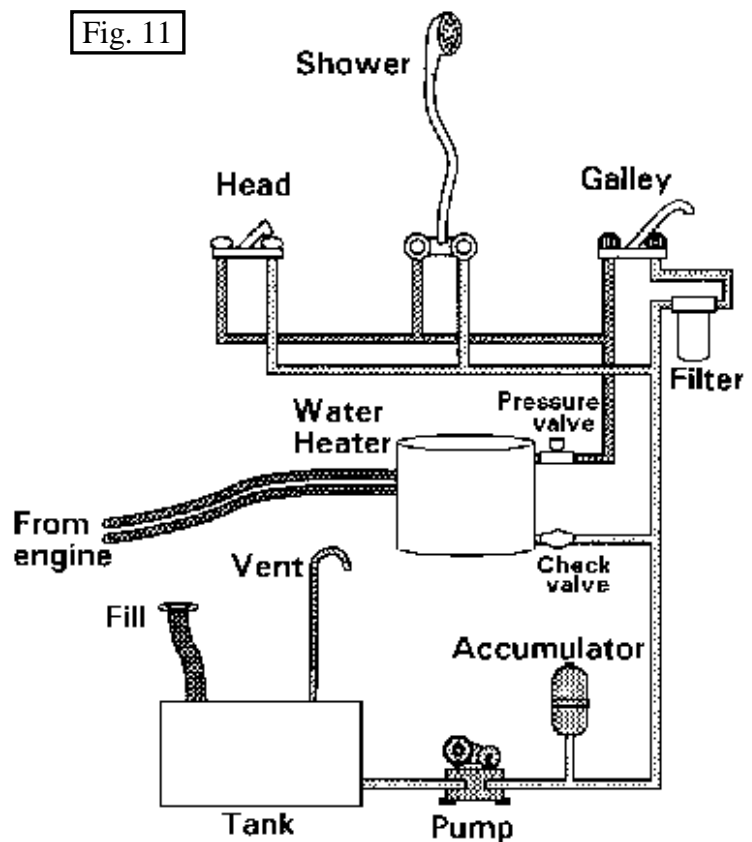

**Decontaminating:**

If the vessel has the ability to siphon lake water into a holding tank, the entire plumbing system will need to be decontaminated, including the tank, heaters, sinks and showers as follows. If the holding tank can only be filled from shore, it will not need to be decontaminated.

2. Sea strainers or filters will usually be found on a raw water system to remove solids. They may also have a more in depth passive water filtration system to bring the water quality to a higher standard.

**Decontaminating:**

Remove the strainer and clean/flush it out.

3. Pumps will be used to pump water into the tank for raw water systems. They will also be used for distributing the tank water around the vessel. The pump turns on when pressure is lost in the system (the sink/shower knob is opened).

**Decontaminating:**

Simply open the faucets, and turn on both hot and cold water at all sinks and showers.

4. Storage tanks simply store the water. There may be several.

**Decontaminating:**

Fill the tank to the top. Drain it by using the faucets as listed above.

5. Accumulators operate passively by allowing pump pressure to build against a diaphragm, and then supplementing the pressure to allow the pump to turn off intermittently while water is flowing. This operates in the same way as bagpipes so that the piper can breath from time to time
6. Check Valves simply make it so that water flows in one direction only. In this case it keeps hot water from going back into the holding tank.
7. Water heaters can either be electric (using a heater coil) or hydronic (using the heat from the engine coolant when it is on) or both (allowing it to switch from one to the other for efficiency).

**Decontaminating:**

See Hydronic/circulating coolant furnaces in Cabin Heaters.

8. Pressure Valves operate to release pressure on a system with a heater in the case the pressure becomes too high as the water is heated.
9. Sinks may be plentiful on the vessel (3 or more). They usually drain the water through a through-hull directly outside the vessel.
10. Showers use the same system as a sink, but because the drain is, or may be, below water line, they require a pump to discard the used water. To prevent the shower water steam from filling the cabin, the drain pump is usually inside a sealed box in the center bilge.



**Decontaminating:**

Showers rarely need to be decontaminated, as they are usually only fed by fresh (not raw) water. But if they are fed by raw water, the entire system will need to be activated, including the shower drain pumps in the bilge.

11. Raw Deck Showers don't usually waste clean water to wash the hull or deck of the boat. They have a separate intake/sea cock, sea strainer and pump that take raw water directly from the lake. The pump then runs to the shower nozzles throughout the boat. They usually have a switch on the dash. In some cases a hot water option is found. This is either water that is run through the engine cooling system directly, or through a hydronic water heater that uses engine coolant water to heat up the shower water. Either way, if there is a hot water option on your raw water shower, it will have to be turned on when the engine is being decontaminated. If the shower gets its water from a separate intake (not directly from the engine cooling system), you will have to supply water to that pump as well as the engine.

Raw Water Deck Shower



**Decontaminating:**

Clean the sea strainer, hook up water to the intake and activate the shower with the trigger pulled. If it is hooked to a water heater, make sure to turn on the hot water to decontaminate those lines as well. Remember to decontaminate the heater while running the engine. See Cabin Heaters: **Decontaminating:** (pg. 70).

## Heads

Toilets on a boat are referred to as heads. They are illegal to dump in coastal waters (<3miles out) and inland waters (lakes and rivers). Some only have the ability to dump overboard. Some have a holding tank to allow them to use the head when they are not in open-ocean. These will have a “Y” valve to select the destination of the waste (tank or overboard). The “Y” valve may be before or after the tank. It must be sealed by the Coast Guard when on inland waters to ONLY use the tank system. All tanks have a hose that is set up to vacuum it out when at a service station.

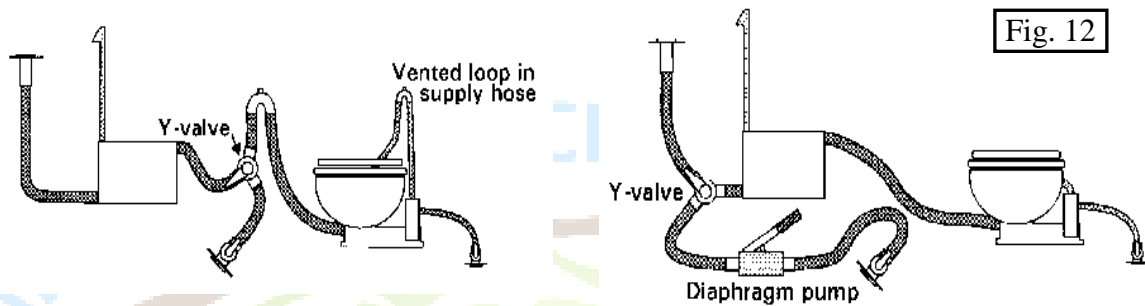

Toilets on a boat may be one of 5 different kinds: portable, hand pump/electric pump, macerator, vacuum, and jet.

- Portable units are small units that have a holding tank on board like a porta-potty.
- Manual/electric head pumps use either a manual or electric pump to push water into the bowl, which then gravity drains into the holding tank.



Hand Pump style Head

- Macerator heads use a motor with blades to chop solids in the waste before entering the tank, or before discharge into open water.
- Vacuum heads use a jet to create a vacuum which sucks clean water into the bowl and waste out into the holding tank.
- Jet heads use high pressure water jets to clear the bowl, but gravity drains the contents into the holding tank.

### Decontaminating:

In all these systems, there will be a simple intake through the hull which you will supply water to as you flush the toilet several times. There is no need to temp the toilet water. We assume that no AIS are surviving in the tank, and if they were, the contents can not be discharged into the lake legally anyhow. In the rare case that flush water is provided from the fresh water tank, the toilet will not need to be decontaminated.

## Live/Bait Wells

### Live Wells:

Live wells are basins designed to keep game fish alive while on board the fishing vessel. They are also commonly found on pontoon boats. They are quite simple in that they pump lake water into a basin which may sit, or be re-circulated or aerated within the basin.

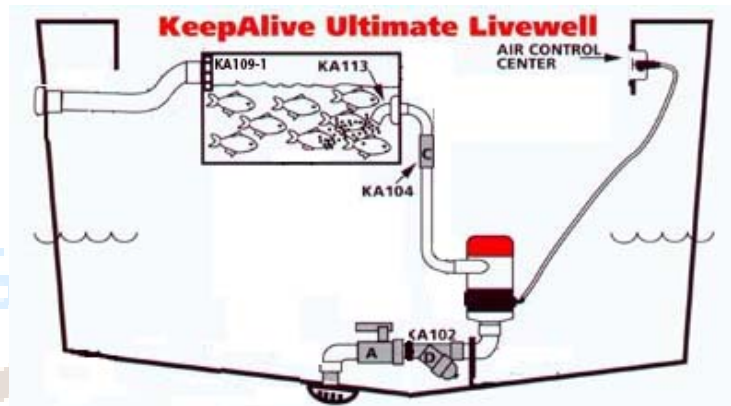

### Bait Wells:

Bait wells are different in that they will constantly bring in new water and push the old water out in order to keep lively and well oxygenated bait fish which need the additional treatment because they are much more fragile than the adult fish they are to lure.

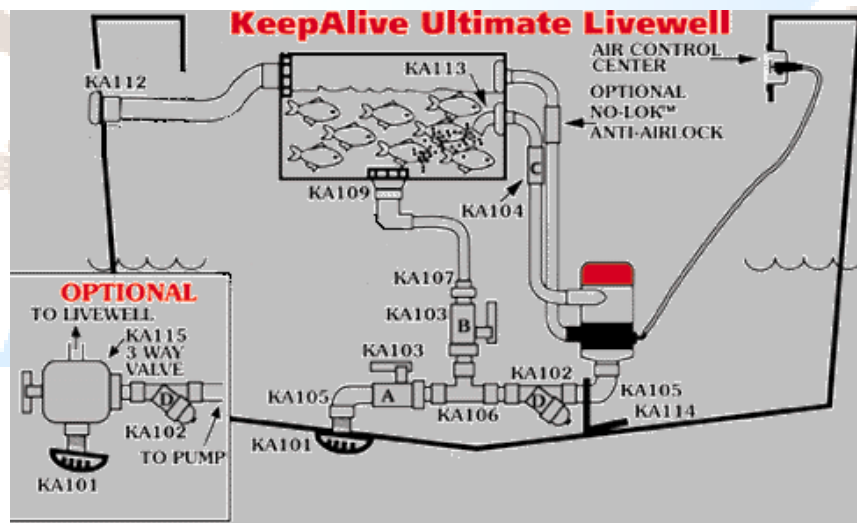

### Decontaminating:

To decontaminate these systems, simply supply water to the through hull where water is picked up from and have the owner run the system as though it were fully operating. This includes recirculation and aeration pumps. In some cases, such as on pontoon boats, the pump is alone and screwed to the outside of the pontoons. In this case, you will have to remove it from the bracket and place it in a bucket of water that you continually fill with hot water. After this is completed, you will run the empty pump to decontaminate that plumbing.

**Examples of Live Well and Aerator Pump Diagrams**

Below are some examples of live/bait wells from the Lund Boat Company. This section is intended to provide inspectors and decontaminators additional information regarding the complexities of wells.

Only low pressure and 140°F water can be used when decontaminating a live/bait well to ensure no damage is done to any of the numerous parts.

The numbers on the following list refer to individual parts shown in all three diagrams.

- 1 - Removable divider
- 2 - drain
- 3 - Fill spray head
- 4 - Overflow
- 5 - Freshwater pickup
- 6 - Waterproof light
- 7 - Freshwater pickup spray head
- 8 - Recirculating spray head
- 9 - Max-Air intake
- 10 - Recirculating outlet
- 11 - Recirculating pump w/ filtration screen
- 12 - Aerator pump w/ filtration screen
- 13 - Through-hull drain
- 14 - Drain with plug

This a **two-pump design**. One pump fills and aerates the well from above the fish while the other recirculates and injects fresh air via the Max-Air system for the oxygenation.

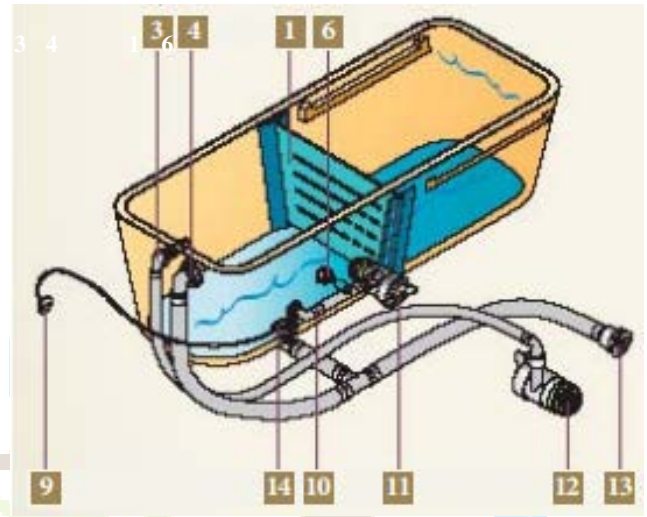

This live well features a **single pump** with a single-switch control. The aerator pump can be run continuously in manual mode or intermittently in automatic mode when equipped with a timer.

DIAGRAMS © LUND BOAT COMPANY AND CRESTLINER BOAT company

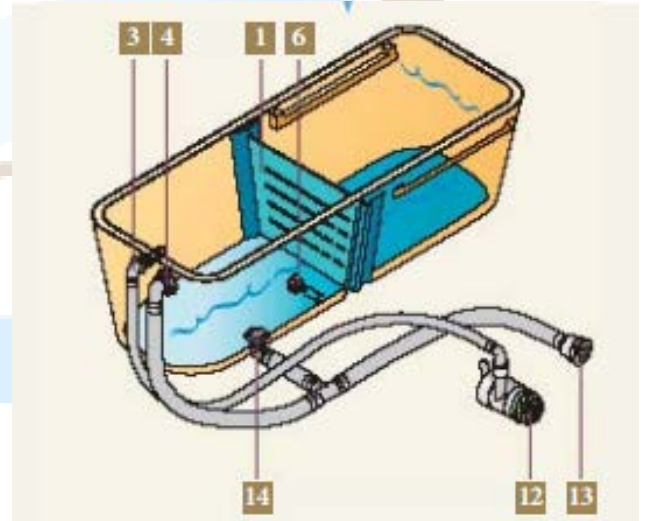
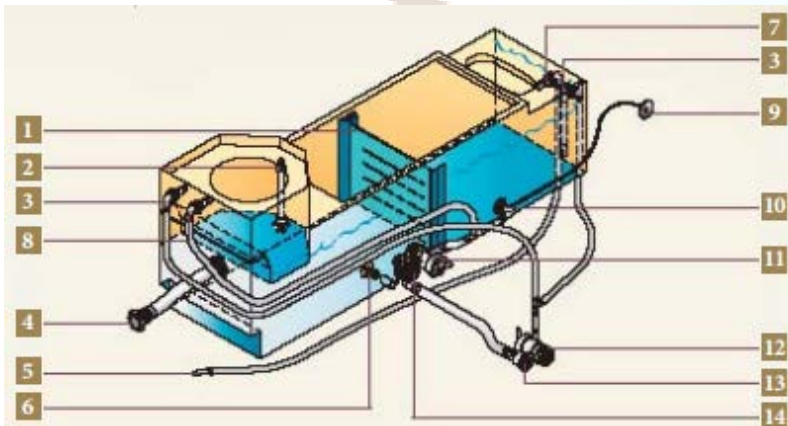

The ProLong Plus is designed with a freshwater pickup integrated into the bottom of the hull where it forces a steady flow of water into the live well while the boat is running.

# Chapter 7: Boat Terminology

## Foreward

**Aft** - Naval terminology, meaning towards the stern (rear) of the boat.

**Anchor storage** - An interior compartment area on the boat, typically in the bow of the boat, where the anchor is stored.

**Bait well** - An interior compartment that specifically holds live aquatic bait. Sometimes it is a separate container on the boat or incorporated in the live well compartment. May also be a pull out bucket in a live well.

**Ballast tank** - A compartment within a boat, ship or other floating structure that holds water. Adding ballast to a vessel lowers its center of gravity, and increases the draft of the vessel. A ballast tank can be filled or emptied in order to adjust the amount of ballast force. Small sailboats designed to be lightweight for being pulled behind automobiles on trailers are often designed with ballast tanks that can be emptied when the boat is removed from the water.

**Bilge** - The lowest compartment on a boat where the two sides meet at the keel. The word is sometimes also used to describe the water that collects in this compartment. Water that does not drain off the side of the deck drains down through the boat into the bilge.

**Bilge plug** - A plug located either on the transom wall or on the bottom of the hull that keeps lake water from entering the boat. It is removed when exiting the water body to help drain any water that has accumulated during the time on the reservoir.

**Bilge pump** - A water pump used to remove excessive bilge water. The water that collects in the bilge must be pumped out to prevent the bilge from becoming too full and threatening to sink the boat.

**Bow** - A nautical term that refers to the forward part of the hull of a boat.

**Centerboard** - A retractable keel which pivots out of a slot in the hull of a sailboat, known as a

centerboard trunk. A centerboard is used to provide lift to counter the lateral force from the sails.

**Complex Boat** - A boat that has one or more interior compartments, a closed hull or more than one motor.

**Daggerboard** - A retractable keel used by various sailing craft. While other types of centerboard may pivot to retract, a daggerboard slides in a casing. The shape of the daggerboard converts the forward motion into a windward lift, countering the leeward push of the sail.

**Fish box** - An interior compartment in a boat where fish are kept.

**Foreward** - Naval terminology, meaning towards the bow (front) of the boat.

**Gimbal** - A pivoted support that allows the rotation (up and down and side to side movement) of the outdrive of an I/O engine and outboard motor.

**Hull** - The body or frame of a boat.

**Inboard engine** - A marine propulsion system enclosed within the hull of the boat.

**Inboard/outboard engine** - (I/O) is located inboard just forward of the transom (stern) and provides power to the drive unit located outside the hull.

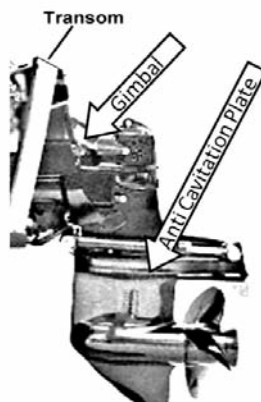

This drive unit (or outdrive) resembles the bottom half of an outboard motor.

DIAGRAM © WEN BALDWIN,  
PSMFCANS TRAINING CONTRACTO

**Jet boat** - A boat propelled by a jet of water ejected from the back of the craft. It uses an impeller to draw the water from under the boat and expel it through a nozzle at the stern.

**Keel** - Runs in the middle of the boat, from the bow to the stern, and serves as the foundation or spine of the structure, providing the major source of structural strength of the hull. Keels are different from centerboards and other types of foils in that keels are made of heavy materials to provide ballast to stabilize the boat. Keels may be fixed, or non-movable or they may retract to allow sailing in shallow waters.

**Live well** - An interior compartment found on many fishing boats that is used to keep caught fish alive. It works by pumping fresh water from the water body into the tank, as well as keeping the water aerated.

**Pitot tube** - A pressure measurement instrument used to measure the velocity of a boat. The Pitot tube is usually attached to the transom.

**Live well pump** - A pump that assists in filling a live well with lake water.

**Lower unit** - The bottom portion of an outboard motor or an inboard/outboard engine. The water found in this portion is lake water that has not been heated by the motor/engine.

**Outboard motor** - A propulsion system for boats, consisting of a self-contained unit that includes engine, gearbox and propeller, designed to be affixed to the outside of the transom and are the most common motorized method of propelling small watercraft. As well as providing propulsion, outboards provide steering control, as they are designed to pivot over their mountings and thus control the direction of thrust. The skeg also acts as a rudder when the engine is not running.



**Port** - A nautical term that refers to the left side of the boat as perceived by a person who is in the boat facing the bow.

**PWC - Personal Water Craft:** A recreational watercraft that the user sits or stands on, rather than inside of, as in a boat. Models have an inboard engine driving a pump jet that has a screw-shaped impeller to create thrust for propulsion and steering.



**Rudder** - A device used to steer a boat when moving through water. A rudder operates by redirecting the water past the hull, thus imparting a turning motion to the craft.

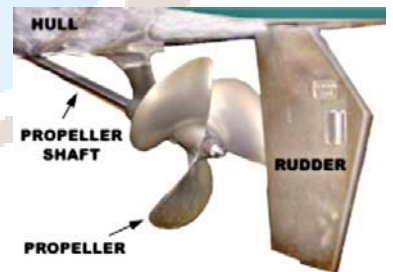

DIAGRAM © BOATCOURSE.COM

**Sailboat** - A boat propelled partially or wholly by sail.

**Simple boat** - A boat with an open hull, no containers or compartments and a single outboard motor.



**Transom well** - A recessed area where water collects that is formed by the transom. Good examples of this are the stern of a pontoon boat or the area where an outboard motor is attached.

**Trim tabs** - The small surfaces (shelves) that are connected to the transom on a boat.



The trim tabs are used to adjust the pitch altitude of the boat while underway. Trim tabs are mostly found on cruisers, sport fishing boats and center console boats ranging from 20 feet and up.

**Starboard** - A nautical term that refers to the right side of the boat as perceived by a person who is in the boat facing the bow.

**Stern** - The rear or aft-most part of a boat.

**Transducer** - An instrument that projects a sound wave into the water. When the wave strikes something such as a fish, it is reflected back and displays size, composition, and shape of the object on a screen inside the boat.

**Transom**—The surface that forms the flat back panel of the stern of a boat. For example: the outboard motor attaches to the transom with either clamps or bolts.

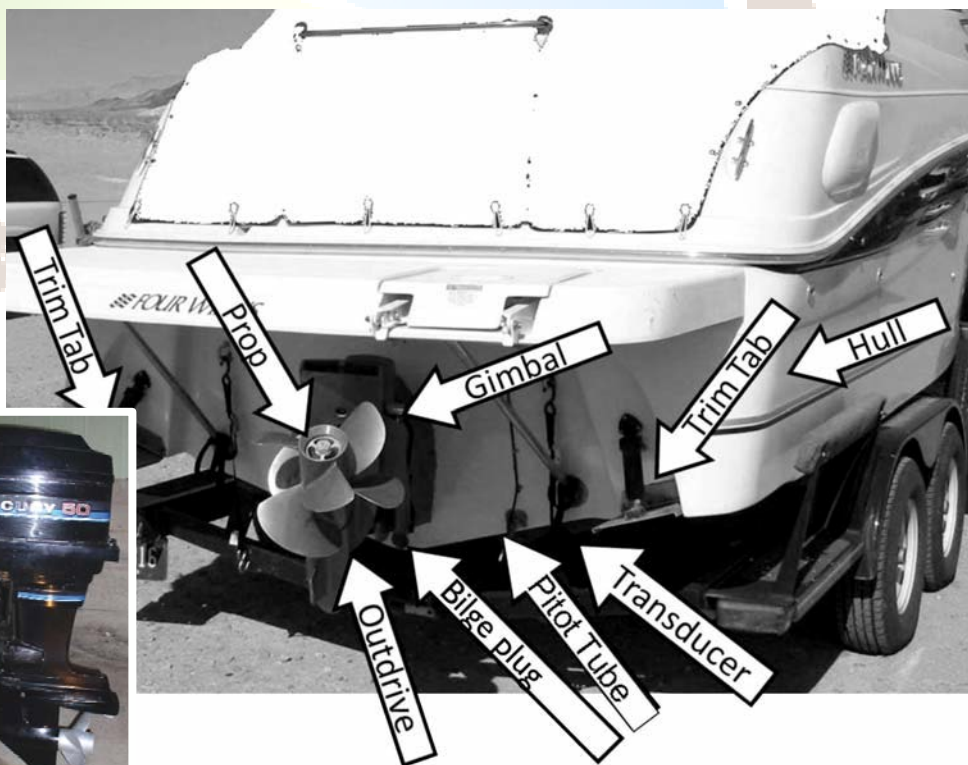

# Chapter 8: Specific Manufacturers

## Fishing Boats:

### Alumacraft

Alumacraft has been manufacturing aluminum, outboard driven boats since 1946. They focus on fishing boats from 10 feet to 20 feet 8 inches and have many different styles of boats ranging from simple to complex.



PHOTOS AND DIAGRAMS ©

ALUMACRAFT

The **Trophy** fishing boat models are featured in their Sport and Fish boat series. They have live wells, bait wells, numerous storage areas, and a bilge area with a bilge pump.

Another model of the Sport and Fish boat series is the **Tournament Sport** boats. These have larger sized live wells (12 to 30 gallons) that must be thoroughly drained prior to the boat leaving the reservoir.

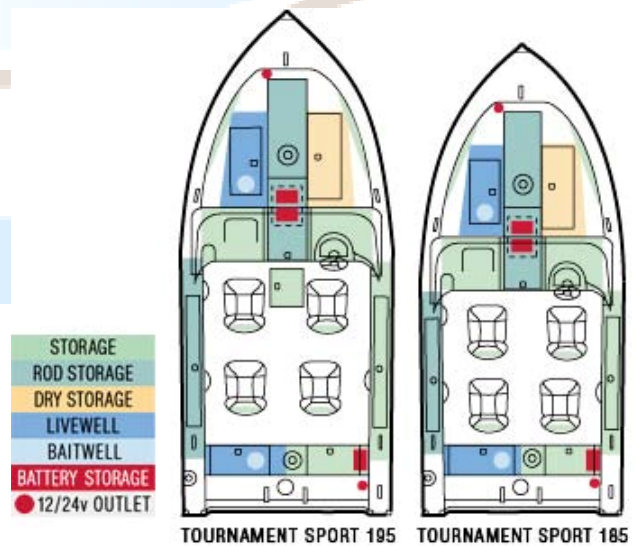
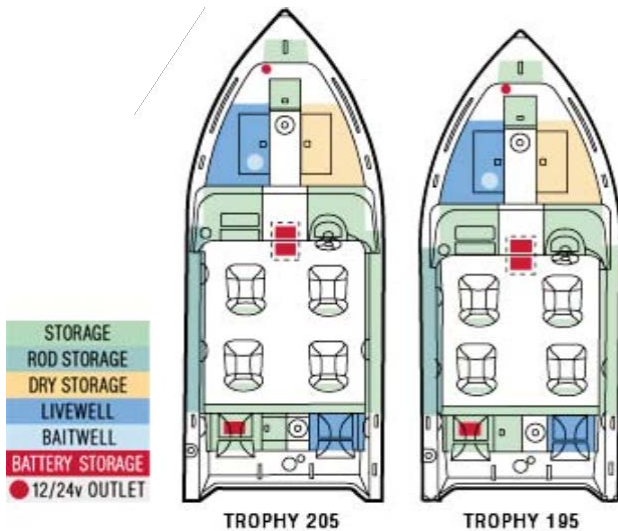



The riveted **Jon** boat series has numerous models; some are simple boats with no compartments and a single outboard motor, while others have storage compartments or a live well.

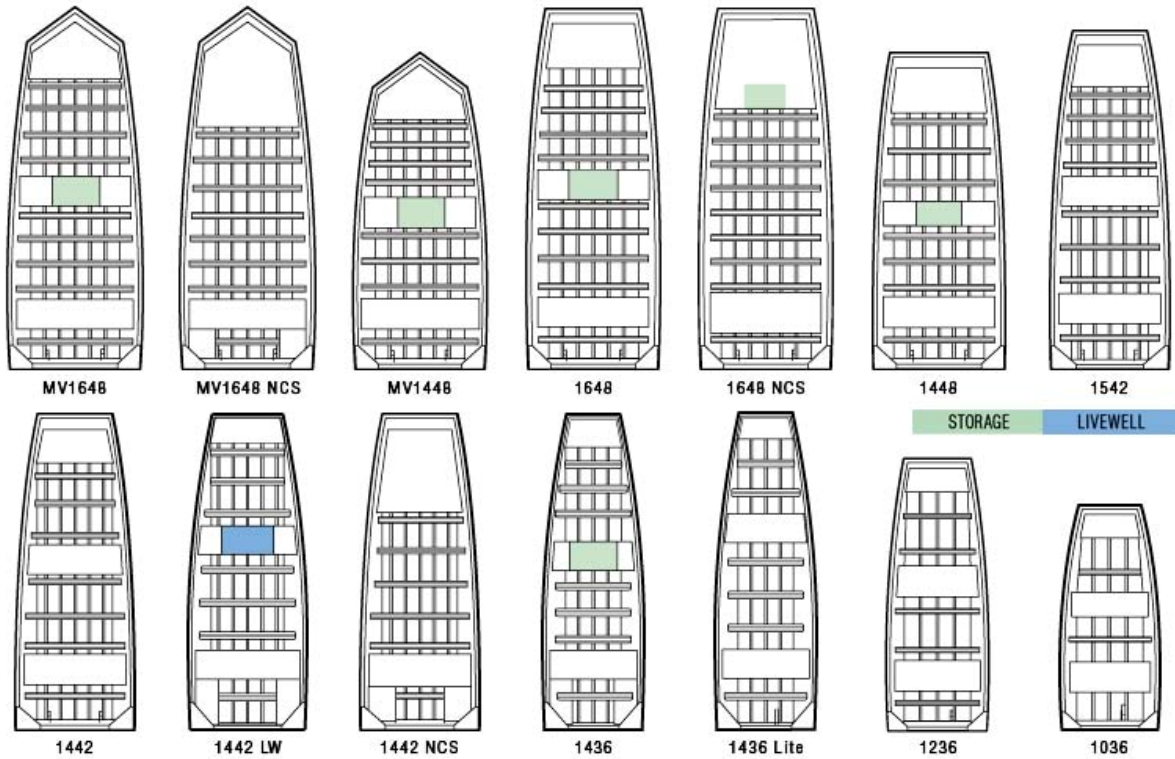

DIAGRAMS © ALUMACRAFT

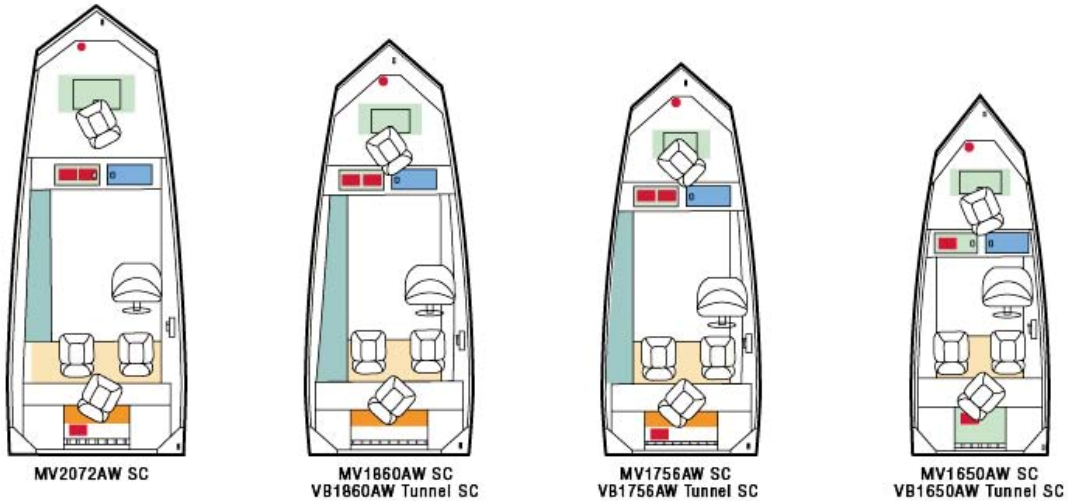

# Lund

Lund boats are a popular brand used by many fishermen across the country. They manufacture six different series of styles, which include: the **Rebel Series**, **Sportsman Series**, **Tournament Series**, **Sport & Fish Series**, **Jon Boat Series**, and the **Wilderness Series**. Each series has a unique style and placement of the storage compartments, live wells, bait well, and bilge area.

All Lund boats, except for some of the Wilderness Series and Jon Boat Series, have a bilge pump and a live well with a possible attached bait well.

Following are diagrams of some of the series models. The **storage compartments** are colored **green**, the **live wells** are colored **blue**, and the **bait well** is colored **orange**. **Yellow** indicates **seating** and the **fuel tank** is colored **pink**.

## Jon Boat

The Jon Boat models are #1436L, #1236, #1232, and #1032. These would be classified as a simple boat (an open hull design with no interior compartments).

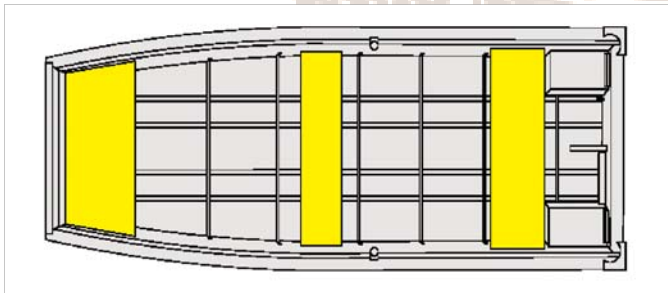

Other models of the Jon Boat series have a small live well (in blue) and a storage compartment (in green) in the center of the boat.

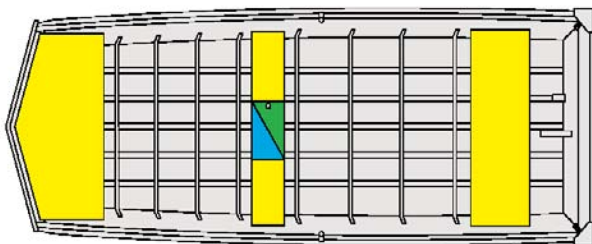

## Wilderness

The Wilderness Series models that would be categorized as a simple boat are: WC-#12, #14 and #16; the SSV-#14, #16, and #18; the A-#12 and #14; and the WD-#14. Below is an example for that Series.

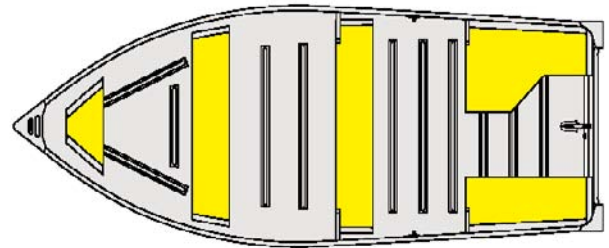

The more complex boats in the Wilderness Series either have a live well located in the forward area of the boat or a live well with a bait well located on the port side of the boat. An example of a live well (in blue) and the bait well (in orange) are seen in the diagram of the 1600 Alaskan SS model below.

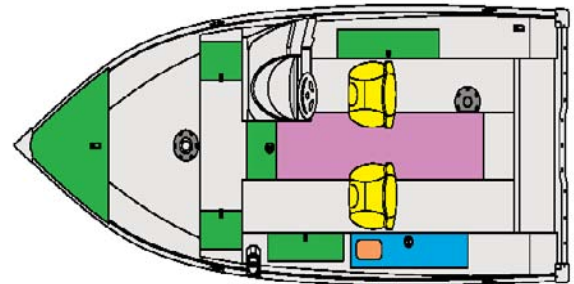

### Sport & Fish

In the Sport & Fish Series, there are four models, the 2150 Baron, 1950 Tye, 1850 Tye and the 1750 Tye. These all have two live wells located in the forward starboard side and in the rear of the boat. The **2140 Baron** and the **1950 Tye** both have a bait well in the rear live well area. They also have two high-capacity bilge pumps. Below is a diagram of the **1750 Tye** with the two live wells (in blue), and numerous storage compartments (in green).

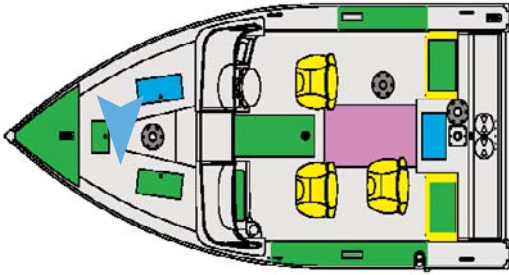

### Sportsman

The focus on the Sportsman Series models is big decks, big storage and big capacity live wells. Most of the models will have two live wells, one aft and one bow, with many having an 18 gallon capacity and bait well. Depending on the model, they usually have a one manual bilge or one manual/auto bilge. The two models of the **Sport Angler, 1800 and 2000**, may have a wash basin as optional equipment. This area needs to be inspected and possibly flushed during the decontamination process.

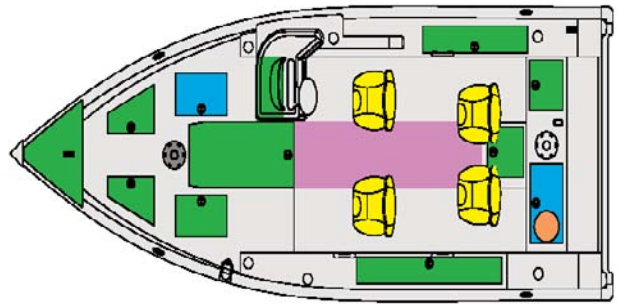

### Tournament

The Tournament Series models have a huge bow casting platform which doubles as extensive storage. They have an aft bait well, a 27.5 gallon aft live well and a 10 gallon bow live well on the starboard side. They also have two high-capacity bilge pumps. These models are very complex and added time is needed in order to complete an inspection.

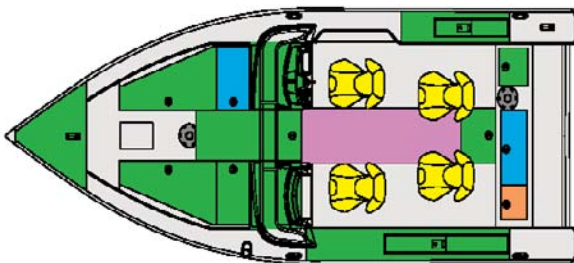

### Rebel

The Rebel Series models are known for their live well systems and numerous storage compartments. All models have one manual bilge pump. The **XL** models have a 20 gallon aerated live well with a bait well. All other models have an aerated 10 gallon live well.

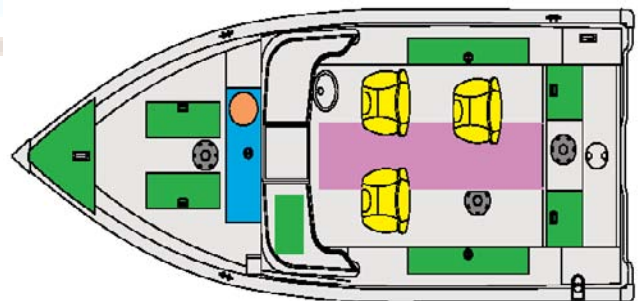

DIAGRAMS © LUND

On page 76, there is a diagram of the three live well models that are featured on Lund boats. They all have plugs and pumps.

# Ranger

**Ranger** has been manufacturing boats since 1968. Today they have more than 40 different models and five different series: **Bass, VX/VS, Fish-N-Play, Multi-species,** and **Saltwater.**

## Bass Series

The Bass Series has 12 models available. One of the most popular in this Series is the **Comanche** model.

As shown below, it has a Venturi air and live well pump out system, and numerous storage compartments.



## VX/VS Series

The VX/VS Series is complex in its floor plan. It has numerous storage compartments and a recirculating aerated live well with divider and filter screens.



LAYOUT KEY	
Cooler	Green
Bat./Oil/Acc.	Orange
Storage	Red
Livewell	Blue
Rod Storage	Purple
Fuel	Teal

## Fish-N-Play Series

The Fish-N-Play Series has three models with numerous styles available: **Reata, Angler,** and **SS.**

The Reata shown below has larger seat capacity and is complex.



The SS model shown below has two live wells, a bow ladder area, and even more storage compartments.



# Tracker

The **Tracker** lineup includes a full range of **Mod V** fishing boats, **Deep V** fishing and **Sport** boats, plus **Jon** and utility boats. The **Jon** and utility boats include options which have basic unpowered boats with only bench seats in the interior.



However, a number of their models do have bow and aft aerated live wells with bait well inserts, rod storage and equipment storage compartments.

As with other manufacturers, the differences between the models include size, equipment, and seating arrangement.



PHOTOS AND DIAGRAMS © TRACKER MARINE GROUP

# LAKE TAHOE EIP

# Trophy

**Trophy Sportfishing Boats** offer a full line of fishing boats. Models include: **Bay Boats** (19–24 feet), **Center Consoles** (17–22 feet), **Dual Consoles** (22 feet), **Rolled Gunnel Series** (16–18 feet), and **Walkarounds** (18–23 feet).

## Bay Boats

These models have two live wells and some have an insulated fish box. These must be inspected to make sure they are dry. These models also come with a bilge pump that must be activated to make sure the bilge and its discharge hose are water free.

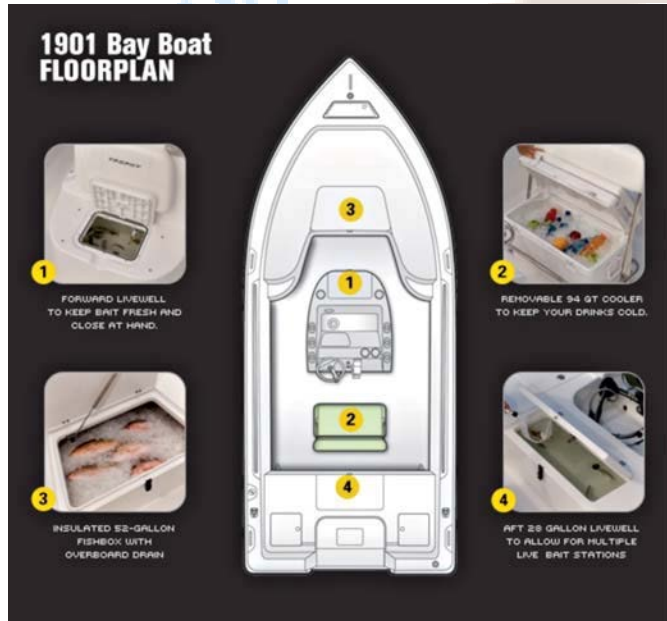

DIAGRAMS AND PHOTO © US MARINE



## Center Console

There are four models of the center console manufactured by Trophy Sportfishing. They include the **1703** which has a 13 gallon live bait well, the **1903** which has a 18 gallon live bait well, the **2203** which has a 35 gallon live bait well and the **2803** which has a 25 gallon live bait well. Each of these models has a bilge pump with an exit through hull discharge port on the aft side of the hull. See the floorplan below for an example of the well placement.



## Rolled Gunnel Series

There are three models in this series: **163 Center Console** which is 16 feet and typically has no live/bait well; **181 Bay Boat** which is 17 feet 17 inches and sometimes has a live/bait well under the center seat cushion; and the complex **183 Center Console** which is 17 feet 17 inches and has a bow storage area, recirculating bait well under the center seat cushion, and two storage areas in the aft port and starboard areas of the boat.

## Dual Consoles

As shown below, the **Dual Console** is a complex boat with fish boxes, a sink with storage area and a 35 gallon aerated live well.



## Walkarounds

These are the “cabin cruisers” of the fishing boat. They can be equipped with 16 to 25 gallon live wells, fish boxes, and raw water deck showers. They are large boats starting at 17 feet 17 inches to over 27 feet.

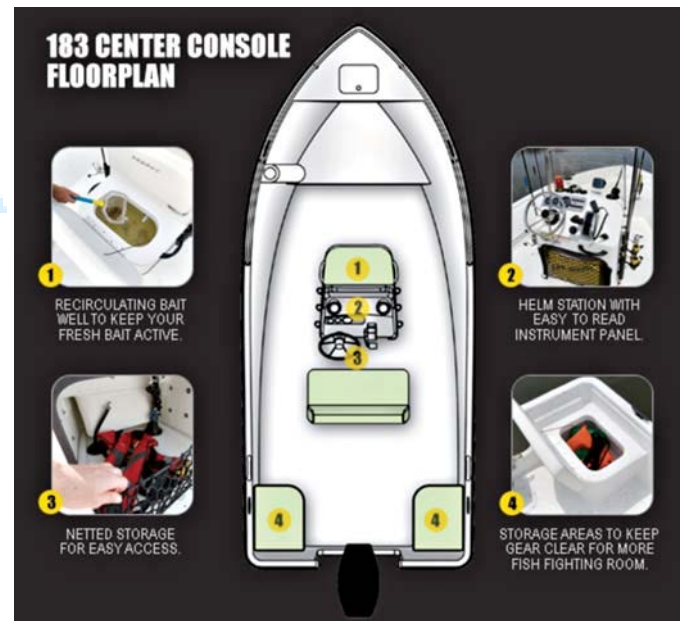

# Pleasure Boats:

## Bayliner

**Most Popular Models:** Runabouts, Cuddys, Deck Boats, Cruisers, Bowriders.

**Bayliner** boats have been manufactured for over 50 years. They have too many models and types to publish. Our attempt is to focus on the most popular models and the specific areas that a boat inspector should be aware of in order to complete an inspection and decontamination.



When inspecting the exterior hull of a boat such as the Bayliner Cruiser series, the inspector may not be familiar with many of the items. This is when it is important to ask the boat owner questions about those items so that the inspector is doing a complete inspection and ensure a safe and effective decontamination.

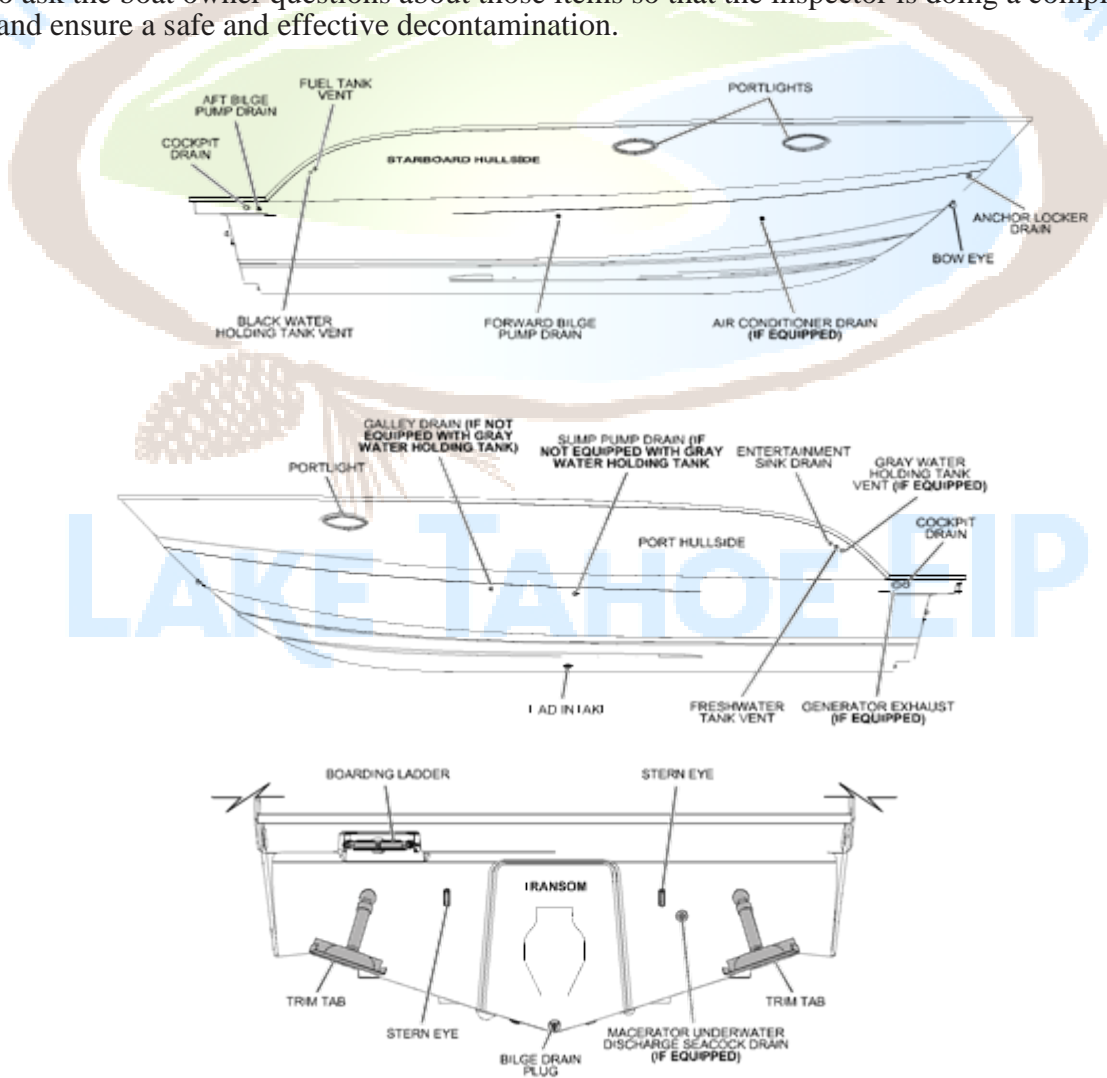



All models have storage compartments which could hold an anchor or equipment such as skis, life jackets and other water gear that could have come in contact with the water body. Some have under-seat storage, cockpit floor storage, bow storage compartments (some dedicated and others hidden behind the backrests) and cockpit deep in-deck storage lockers.



Many of the swim ladders have a hide-away cover and can be located either in the front or back areas of the boat.

The Cruiser Discovery model has an under seat live well option which is quite hidden. The inspector needs to ask the boater if they have a live well so that this very important compartment is inspected. Never assume that a boat does not have a live well.

A few of the models have aerated live wells. Examples of this may be found on: 185 Ski N Fish, Bowriders, 195 Discovery, Cuddy 192 Discovery, and the Cruiser 266 Discovery.

The Bayliner models that are equipped with an inboard/outboard have a bilge pump in the engine compartment. The inspector can identify the pump's manufacturer and then adjust their decontamination unit's temperature accordingly.

This photo shows a Johnson pump that is temperature rated at 170°F. Please note how it is lifted off the bottom of the interior hull. Water will still be present after this pump has been activated and no more water exits through the thru-hull drain.



The Cruiser boat series have two bilge pumps thru hull discharge drain. Each of these pumps during inspection and decontamination. this diagram emphasizes the need to first run water into the thru hull fittings due to the length of the hoses between the pumps and the exterior of the hull.

with their corresponding hoses will need to be activated. During decontamination the low pressure hot water length of the hoses

Bayliner Overlay:

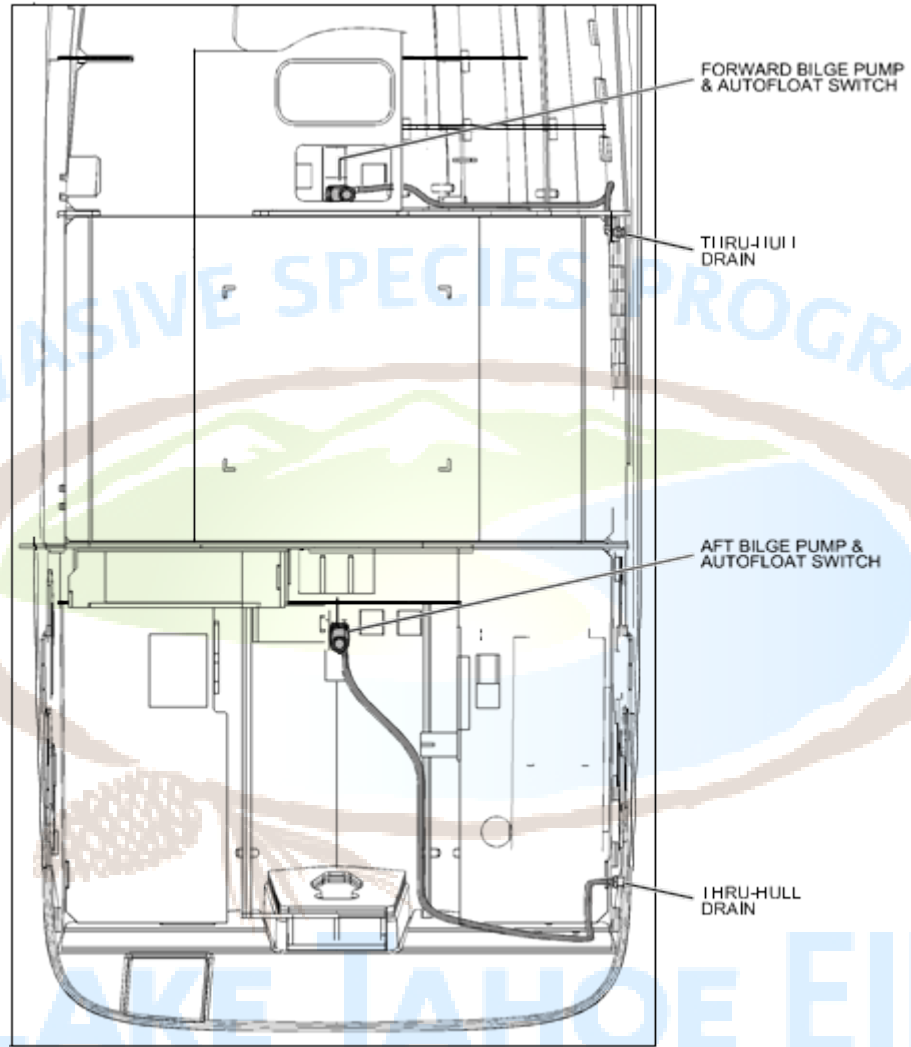

# Maxum

Maxum boat manufacturer has three types of boats: **Sport Boats**, **Sport Cruisers**, and **Sport Yachts**. Each type has numerous models each with unique challenges to a boat inspector.

## Sport Boats

Their sport boats usually come with either an inboard/outboard engine or true inboard engine. Within the engine compartment they have a bilge pump and corresponding discharge through a hull fitting on the outside of the hull. They have numerous seating areas with storage under the seat cushions that may hold equipment that has come into contact with the water body. Typically, they have two compartments on either side of the engine compartment that also contains storage areas.

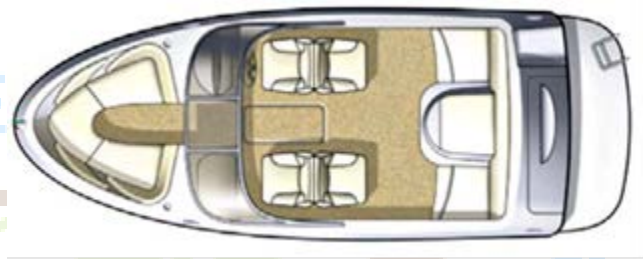

**Sport Cruisers** The cabin cruiser models from Maxum are complex and need to be carefully inspected. Within the engine compartment, they typically have two bilge pumps with their corresponding discharge through hull ports. On deck, there are side storage shelves, storage under seat cushions, and an anchor line hatch and anchor. The transom has, among other items, trim tabs and a transom zinc. Inside the “cabin” area, they have a head and galley. In the Head, they have a sink and shower. In the galley there is also a sink.



The Sport Cruiser comes with a water holding tank (typically 20+ gallons). The boat inspector must ask the boat operator if tap water is used in these areas or if they are using lake water.



### Sport Yachts

The lengths of these yachts are usually 37+ feet. They are equally as complex as the cabin cruisers and must be inspected carefully.

- A head with a sink and shower
- It has an on deck sink
- A galley with a sink

It is important for the boat inspector to find out if the boat operator is using the water storage tank with 30+ gallons of water with tap water or lake water.

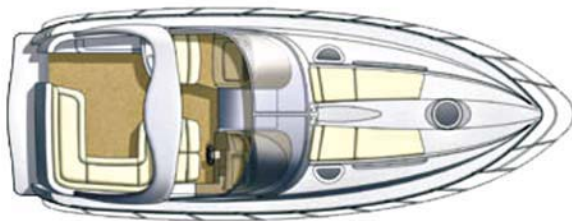
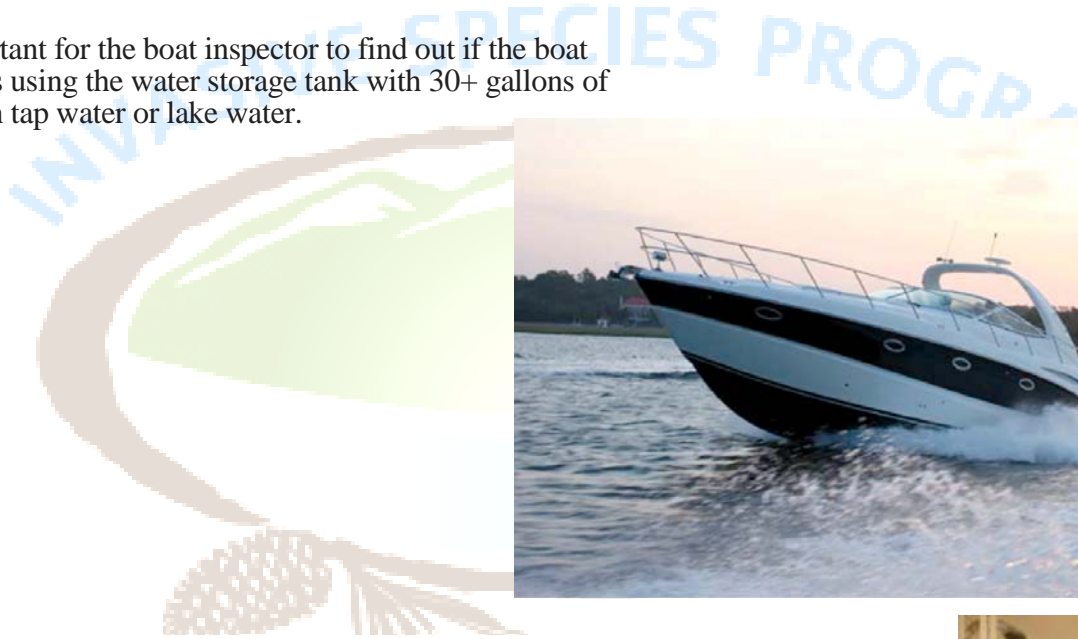

## Chris-Craft

Chris-Craft boats have manufactured boats for over 130 years. They have numerous models and series that include: Runabouts, Cuddy Cabins, Bowriders, and Express Cruisers. They have a line of center console fishing boats that are very complex.

### Catalina Fish Boat Series

These boats may have a helm seat module a 28 gallon live well/bait well; two fish boxes on both the port and starboard sides with a macerator. Fish boxes are typically mounted into the floor of the vessel and are very often bellow the waterline. The Macerator pump is the ideal pump for the emptying of a fish box and live well

receptacles due to its self-priming capabilities and its grinding properties. Typically, there are forward and aft bilge pumps with corresponding discharge through hull fittings, a ladder storage area, and a raw water wash down outlet at the port entry.

There are numerous storage areas underneath the bow seating area. Inspectors must ask the boater to remove the cushions to access and inspect the numerous storage areas underneath.



LAKE TAHOE EIP

# Four Winns

The Four Winns boat manufacturer has five series which include the **H, SS, SL, F,** and **V** Series. Within these series there are numerous models that differ in size and the equipment that is offered.

All of these series boats have interior compartments which make them “complex” boats when determining risk factors. Typically they have anchor storage beneath the bow seat, a storage compartment for the aft ladder, and an in-floor ski locker with a rubber mesh or carpet liner.

For the models that have an inboard or inboard/outboard engine there is an engine compartment that must be inspected for standing water.

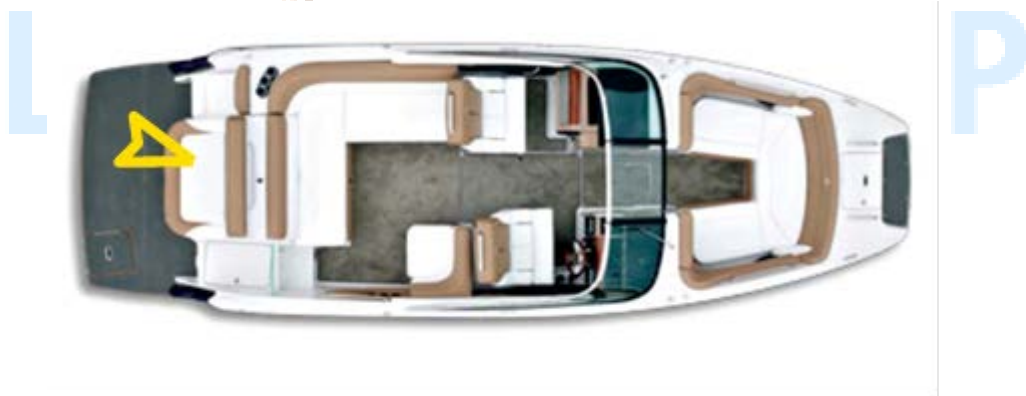

# Pontoon

There are numerous manufacturers of pontoon boats. They include: **Premier Marine, Manitou, Sun Tracker, South Bay, Starcraft Marine, JC Pontoon, Ponder, Ercoa, Landau, and Lowe**

A pontoon boat typically floats and balances by means of two large, closed cylinders mounted lengthwise. Some of those cylinders have vents on top of the pontoons where splashed water can get inside. Other pontoons have welded seals that could leak, trapping water inside.

Typically, pontoons do not have drain plugs or pumps installed to release the trapped water. Some pontoons have partitions creating two or more separate internal compartments.

**The insides of pontoon tanks cannot be visually checked for mussels or other Aquatic Invasive Species (AIS).** These tanks could contain more than five gallons of water even if there are no visible holes.



- Check pontoons for water by knocking on them. If you hear a dull thud, they could be holding water. If you hear a hollow empty sound, the pontoon is most likely dry.
- Put your hand on the pontoon and slide along the surface from top to bottom. Is there a temperature change? If so, the pontoon may be holding water.
- Listen to pontoons. A sloshing sound when stopping the trailer will indicate trapped water in the pontoon.

Pontoon boats can be simple to very complex; some have active live wells with pumps.

The live well pump is usually located in a cage-like area at the end of one of the pontoons. Some of the live well pumps are intake only; some can also assist in the drainage of the live well.



When performing an inspection, the trailers for pontoons are usually quite high off the ground providing the inspector good views of the underside of the pontoon and exposure to the trailer. However, as demonstrated by the photos below, there are lots of areas where AIS attachment is possible. During decontamination, the inspector has to be very meticulous and contact every portion with 140°F water and high pressure. Please note the large areas of carpeted bunks; these must be decontaminated with 140°F water at low pressure.



Pontoons typically have lots of seating with removable seat cushions. The inspector must ask the boat operator to open these areas and inspect the equipment, ropes, and all personal items that may have come into contact with the water body during an inspection.



This photo shows a pontoon that has two pumps located in the cage at the back of the pontoon. One pump is for the live well, the other is for a wash station.





# Sail Boats:

## Grenada Ballast Tank Sailboats

**Grenada** sailboats utilize water ballast which allows the sailboat to be very light for trailering but heavy enough for safe sailing.

Water ballast is carried in the hull as well as the keels, which allows the keels to be thinner, resulting in reduced drag at high speed. The water ballast system is very simple, one valve for each keel. Open the valve and the keel fills (or drains if you're out of the water). Close the valve and the water is captured. If you want more performance, especially in light conditions, pumps may be added to transfer ballast. Each keel contains roughly 20 gallons of water.

In this photo, the sailboat on the left is un-ballasted. However, the one on the right is an example of a twin keel ballast sailboat and the water intake and drainage is the same as the **Grenada 14**.

**Internal and Water Ballast** - The ballast within a sailboat is the weight that pulls the boat upright after a knock down. The lower you can get the weight, the better a chance the boat has of righting itself after a knock down. Some designs have the ballast attached inside the hull in the bilges in the form of concrete and iron, custom molded weights, or **water tanks**. This form of ballast works, but isn't as effective as an externally held ballast. In the case of **water ballast**, fill the tanks when launching your boat and drain them when retrieving it back onto the trailer, so you don't have to pull all that weight on the road.



you  
the  
lead  
you

The Grenada 24 combines the advantages of twin bilge keels and water ballast. The boat can be beached safely, gains stability by placing the water ballast low in the twin keels, and is light enough to be trailered.

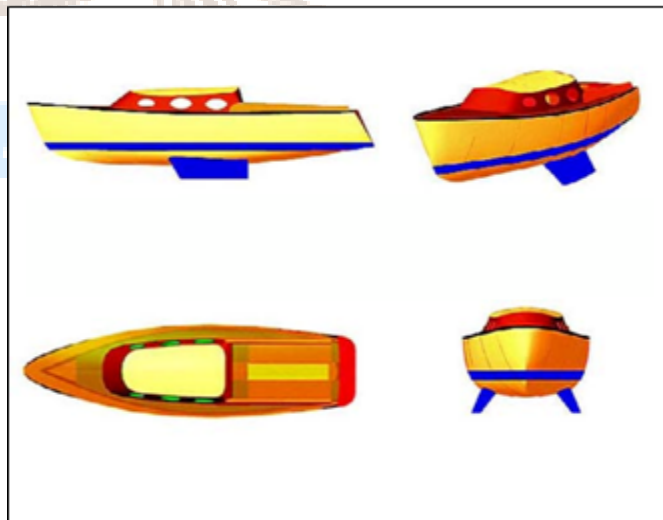

EIP

# Hobie Cat Sailboats

Hobie Cat manufactures two types of sailboats: Rotomolded sailboats with models that include the Bravo, Wave, and Getaway; and Fiberglass sailboats with models that include the Hobie 16, FX One, and Wild Cat.

All of these models are simple to inspect. However the plugs on the back end of the catamarans must be open during the inspection, the rudders clean, and all ropes and equipment must be dry.



There are usually plugs on the back end of the catamarans that must be inspected and decontaminated if necessary.

Many trailers are tubular and may also have a plug or an opening, therefore must be inspected and/or decontaminated thoroughly.



# MacGregor Sailboats

For more information on decontaminating Macgregor Ballast systems, see page 61 under Optional Raw Water Systems/Ballast Systems/9.Ballast Tanks and Bags.

MacGregor sailboats utilize water ballast which allows the sailboat to be very lightweight for motoring or trailering, and also have the heavy stability necessary for safe sailing. After launching, the valve is opened and a tank in the bottom of the hull is gravity filled with 1,150 lbs. of water. It takes about five minutes to fill. The valve is then closed, trapping the water. Under power or sail, the ballast makes the boat stable and self-righting. When the boat is floated back onto its trailer, the valve is opened. The car and trailer start up the ramp and gravity drains water out of the boat, resulting in a trailering package that is lighter than most small powerboats. You can also empty the tank while the boat is in the water. Under power, at about six mph, open the valve on the transom and the tank will drain in about five minutes.

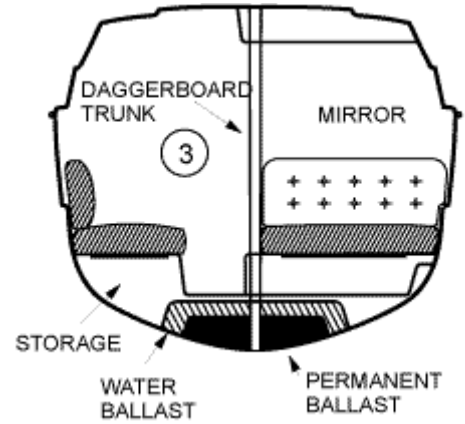

The daggerboard trunk (shown above) contains the daggerboard/retractable keel. This area can't be decontaminated from the top and there is limited space from below to perform a decontamination with a trailer cross member in the way.

A daggerboard is a retractable keel used by various sailing craft. While other types of centerboard may pivot to retract, a daggerboard slides in a casing. The shape of the daggerboard converts the forward motion into a windward lift, countering the leeward push of the sail.

Daggerboards are often long and thin, thus providing a better lift-to-drag ratio. Daggerboards are usually found in small craft such as day sailors, where their size is easily handled by a single person. When a daggerboard is extended through the keel, it improves a ship's stability. Daggerboards can be raised to allow the ship to enter a shallow harbor.



MacGregor 26M Breather Ports

MacGregors are easy to decontaminate but take time. Just shut the valve and fill from the inside breather hole located inside the cabin. Then open valve to drain. On the 26D the fill/drain valve is located under the vessel and is opened and closed from a hand screw in the cabin next to the breather plug(left). On the 26M (above and right)



the breather is inside the cabin. The valve is a hand-pull dagger valve mounted to the transom of the vessel.



MacGregor 26M Drain/Fill

# Ski/Wakeboard Boats:

## Malibu

Malibu has four basic boat models: **Wakesetters**, **Rides**, **Sunscape**, and **Response**. All Malibu boats use inboard marine engines. Many of the boats share hull designs, but come equipped with different features:

- **Wakesetters** include VTX, VLX, 23LSV, and 247LSV.
  - All come standard with three ballast tanks.
  - All may be ordered with an additional front ballast tank.
- **Rides** include 21V and 23V.
  - Both come standard with two rear ballast tanks.
  - Both may be ordered with an optional center ballast tank.
- **Sunscape** includes 20LSV, 21LSV, 23LSV, and 247LSV.
  - Ballast tanks are optional on all models.
  - If ordered, the only option is three ballast tanks.
- **Response** includes LXI and FXI.
  - LXI has no ballast tanks.
  - FXI has one ballast tank.

Intakes for the ballast tanks are located under the hull. Make sure all lines (hoses) in and out are decontaminated. Also look for aftermarket removable ballast bags those must be inspected and decontaminated as well.

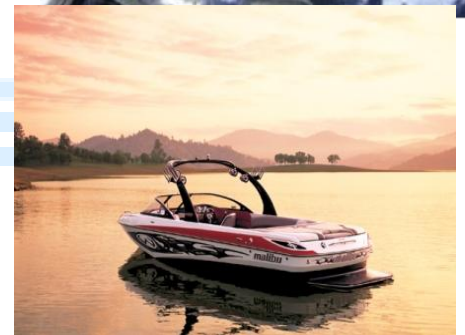

# MasterCraft

Mastercraft has been manufacturing boats since 1968. Their focus is in building ski, wakeboard, and luxury performance powerboats. MasterCraft has numerous models that include: the V, X, Prostar, Maristar, CSX, and the 300.

## V model

The V model has the 220V, 215V, 225V, 235V, 245V, 255V, and 280V. This model has many storage/equipment compartments located in the bow, at the rear of the boat under the expansive sun pad. Many have a compartment for the ladder and anchor located in the bow of the boat.

- The 200V and 215V have I/O engines and bilges with pumps.
- The 225V (comes standard with ballast tanks), 235V, 245V, and 255V come equipped with an inboard engine.
- The 280V has twin inboard engines.

## X Model

The X model has the X-1, X-2, X-7, X-14, X-14V, X-15, X-25, X-30, X-35, X-45, X-55, X-80 and the X-Star. These are all complex boats with storage areas, center drain plug in the floor compartment, bilges, I/O engines and inboard engines.

- The X-1 and X-14V can be ordered with either two or three ballast tanks.
- The X-7 and X-14 have the MTS Ballast System with port, starboard, and rear ballast tanks possible.
- The X-30 has three ballast tanks, two in the back and one forward.
- The X-2, X-15, X-35, X-45, and X-55 have one ballast tank located under the floor board in the front of the boat. These also have an anchor/ladder storage compartment on the bow of the boat, and forward and aft bilge pumps.
- The X-80 and X-Star have three ballast tanks and twin inboard engines

## Prostar

The Prostar model has the 190, 197, 214, and 214V.

- All Prostar boats have the MTS Ballast System with the option of having a port, starboard, and rear ballast tanks.
- Prostar 190 and 197 have two ballast tanks standard.
- Prostar 214 has three ballast tanks standard.
- They have a bilge through hull fitting on the starboard side.



- There is a center drain plug located in the floor compartment.
- Most of the Prostar boats have a shower wand attachment at the starboard aft.

## Maristar

The Maristar has the 200, 215, 230, 235, 245, 255, and 280 boat styles.

- The Maristar 200 and 215 have a ballast tank located beneath the floor board. They also have a forward and aft bilge.
- The Maristar 230 has three ballast tanks, two in the back and one forward, and a forward and aft bilge.
- The Maristar 235, 245, and 255 have one ballast tank located in the front, a forward and aft bilge, and an anchor/ladder compartment on the bow of the boat.
- The Maristar 280 has three ballast tanks and two twin inboard engines.

## CSX

The CSX model has the 220 and 265 boats available. It is the only model that has a fishing package as an option.

- CSX 220 comes with three ballast tanks, forward and aft bilge pumps and an anchor/ladder compartment on the bow.
- CSX 265 has three ballast tanks, three bilge pumps, twin inboard engines and an optional live well.

## Tournament

The Master Craft 300 is the cabin cruiser of the line. It comes with twin inboard engines, anchor/ladder compartment in the bow, a sink and shower, and bilge pumps. The engine compartment is located in the floor of the boat in the aft. There are numerous storage compartments for ski and wakeboarding equipment.



